



6390 Philips Highway
Jacksonville, FL 32216
Phone (904) 737-7144

SPECIFICATION DATA SHEET

MODEL No. 1243

INSULATED FLOOR BOOT

Date: 10/26/15

Drawn by: DON. JR.

DIMENSIONAL DATA

OUTER BOX DIMENSION IS 2" GREATER THAN REGISTER DIMENSION.

FABRICATION DATA

MATERIAL:
30 GAUGE GALVANIZED STEEL SHEET PER
ASTM A653 CS TYPE B.

INTERNALLY INSULATED WITH R-4.2 INSULATION.

FEATURES

1" FLANGE UP FOR FLOOR THICKNESS.

BLACK INTERIOR.

SOLID CORNERS.

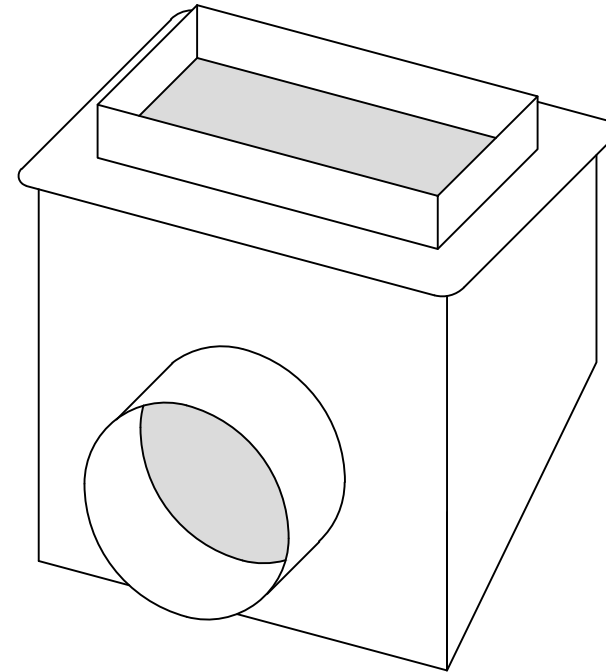

OPTIONS

SPECIAL NOTES

INTERNAL INSULATION USED MEETS THE REQUIREMENTS OF ASTM C 1338 (FORMERLY ASTM C 665) STANDARD TEST METHOD FOR FUNGI RESISTANCE.