



6390 Philips Highway
Jacksonville, FL 32216
Phone (904) 737-7144

SPECIFICATION DATA SHEET

MODEL No. 316-DSO

TAKE OFF COLLAR FOR ROUND PIPE WITH
GASKETED FLANGE, MANUAL VOLUME
DAMPER, DAMPER HANDLE STANDOFF AND SCOOP

Date: 10/12/20 rev.

Drawn by: J.E.P.

DIMENSIONAL DATA

DIAMETER	TO FIT PIPE SIZE
4"	8"
5"	9"-10"
6"	10"-12"
7"	10"-12"
8"	12"-14"
9"	12"-14"
10"	14"-16"
12"	16"-18"
14"	18"-20"
16"	20"

FABRICATION DATA

MATERIAL:
HOT DIPPED GALVANIZED STEEL SHEET
PER ASTM-A653 CS TYPE B.

GAUGES:
4" THROUGH 9" = 30 GAUGE
10" THROUGH 16" = 28 GAUGE

FEATURES

CONTOURED FLANGE WITH 1/2" WIDE
GASKET DESIGNED TO MOUNT
TO ROUND PIPE.

SCOOP IS WELDED AT FLANGE TO PENETRATE
INTO TRUNK DUCT.

CRIMPED MALE CONNECTION FOR BRANCH DUCT.

MANUAL VOLUME DAMPER INSTALLED.

2" DAMPER HANDLE STANDOFF.

MANUAL VOLUME DAMPER WITH 1/4" CONTINUOUS
ROD DAMPER AXIS WITH LOCKING REGULATOR,
GROMMETS INSTALLED AT THE COLLAR
PENETRATIONS.

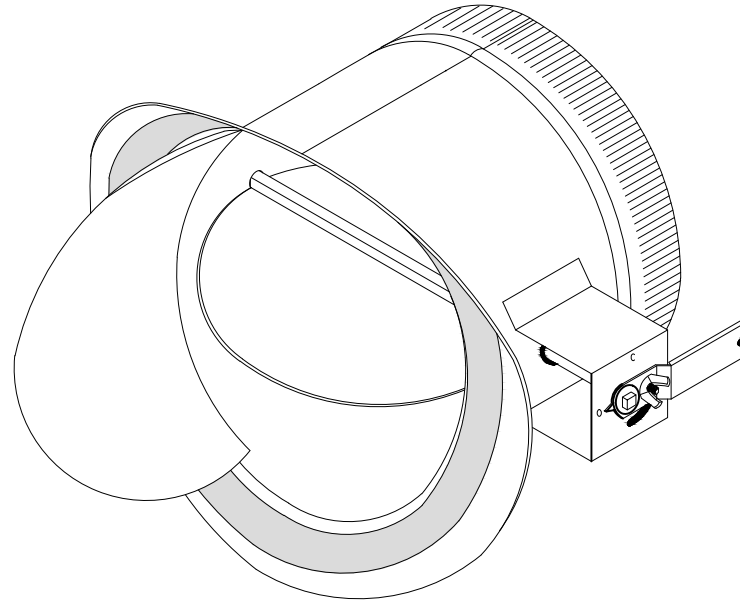

SPECIAL NOTES

RECOMMENDED INSTALLATION: DAMPER AXIS PARALLEL TO AIR FLOW.