



6390 Philips Highway  
Jacksonville, FL 32216  
Phone (904) 737-7144

## SPECIFICATION DATA SHEET

**MODEL No. 798**  
**1 1/2" WIDE HANGER STRAP**

Date: 04/10/15

Drawn by: M.D.C.

### DIMENSIONAL DATA

1 1/2" WIDE x 100' ROLLS

### FABRICATION DATA

MATERIAL: FABRICATED FROM GALVANIZED  
STEEL SHEET, ASTM-A653 CS TYPE B.

#### AVAILABLE GAUGES:

30 GAUGE - .013" MINIMUM STEEL THICKNESS  
26 GAUGE - .019" MINIMUM STEEL THICKNESS  
22 GAUGE - .030" MINIMUM STEEL THICKNESS

### FEATURES

100 FEET 1 1/2" WIDE STRAP IN CARTON.

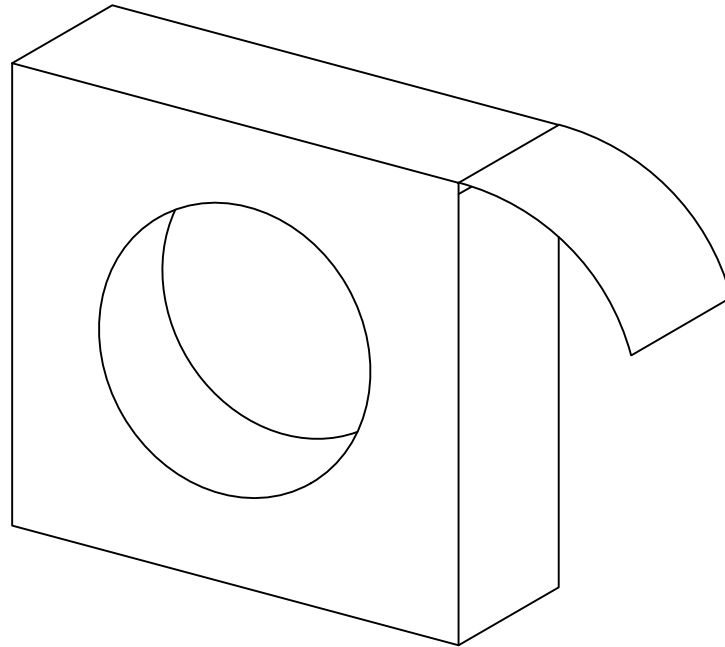

### OPTIONS

### SPECIAL NOTES

MANUFACTURED IN THE U.S.A.