



6390 Philips Highway  
Jacksonville, FL 32216  
Phone (904) 737-7144

## SPECIFICATION DATA SHEET

## MODEL No. 716-DSO

START COLLAR WITH GASKET FLANGE,  
SCOOP, MANUAL VOLUME DAMPER AND  
DAMPER HANDLE STANDOFF

Date: 09/04/19 rev.

Drawn by: Don. Jr.

### DIMENSIONAL DATA

SIZES AVAILABLE: 4" THROUGH 16" DIAMETER

COLLAR LENGTH: 5-1/2" (ALL DIAMETERS)

### FABRICATION DATA

MATERIAL:  
HOT DIPPED GALVANIZED STEEL SHEET  
PER ASTM-A653 CS TYPE B.

GAUGES:  
4" THROUGH 10" = 30 GAUGE  
12" THROUGH 16" = 28 GAUGE

### FEATURES

1" WIDE FLANGE WITH GASKET MATERIAL AND  
PRE-DRILLED SCREW HOLES FOR EASE OF  
INSTALLATION.

CRIMP AND BEAD TRANSVERSE CONNECTION.

OVERLAP AND RIVETED LONGITUDINAL SEAM.

MANUAL VOLUME DAMPER WITH 1/4" CONTINUOUS  
ROD DAMPER AXIS WITH LOCKING REGULATOR,  
GROMMETS INSTALLED AT THE COLLAR  
PENETRATIONS.

SCOOP PENETRATES INTO TRUNK DUCT AIR  
STREAM.

2" DAMPER HANDLE STANDOFF.

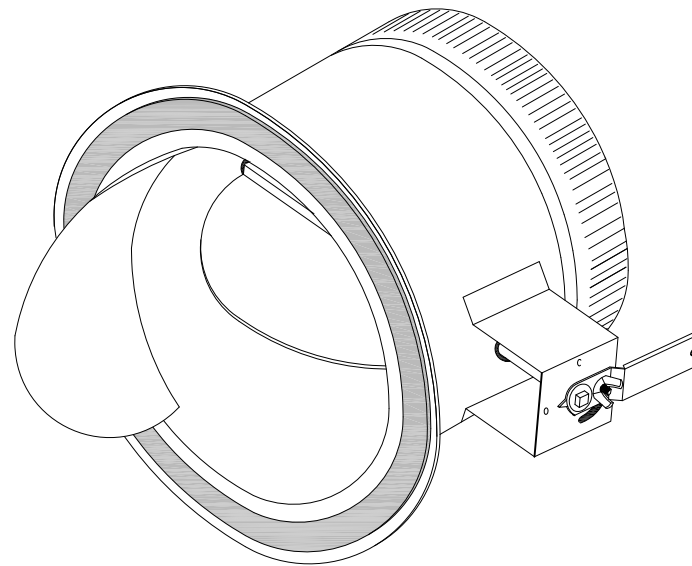

### OPTIONS

No. 710: TAKE OFF WITH THERMA GASKET SEAL

No. 712: TAKE OFF WITH THERMA GASKET SEAL  
AND SCOOP.

No. 714: TAKEOFF WITH THERMA GASKET SEAL  
AND MANUAL VOLUME DAMPER.

### SPECIAL NOTES

RECOMMENDED INSTALLATION: DAMPER AXIS PARALLEL TO AIR FLOW.