



6390 Philips Highway
Jacksonville, FL 32216
Phone (904) 737-7144

SPECIFICATION DATA SHEET

MODEL No. 715-DSO

START COLLAR WITH PEEL OFF GASKET FLANGE,
MANUAL VOLUME DAMPER AND
DAMPER HANDLE STANDOFF

Date: 06/24/19 rev

Drawn by: M.D.C.

DIMENSIONAL DATA

SIZES AVAILABLE: 4" THROUGH 16" DIAMETER

COLLAR LENGTH IS 5-1/2" (ALL DIAMETERS)

FABRICATION DATA

MATERIAL:
HOT DIPPED GALVANIZED STEEL SHEET
PER ASTM-A653 CS TYPE B.

GAUGES:

4" THROUGH 10" = 30 GAUGE

12" THROUGH 16" = 28 GAUGE

FEATURES

1 1/2" WIDE FLANGE WITH GASKET MATERIAL
AND PRE-DRILLED SCREW HOLES FOR EASE OF
INSTALLATION.

CRIMP AND BEAD TRANSVERSE CONNECTION.

OVERLAP AND RIVETED LONGITUDINAL SEAM.

GASKET HAS PEEL-OFF PAPER.

MANUAL VOLUME DAMPER INSTALLED.

MANUAL VOLUME DAMPER WITH 1/4" CONTINUOUS
ROD DAMPER AXIS WITH LOCKING REGULATOR,
GROMMETS INSTALLED AT THE COLLAR
PENETRATIONS.

2" DAMPER HANDLE STANDOFF.

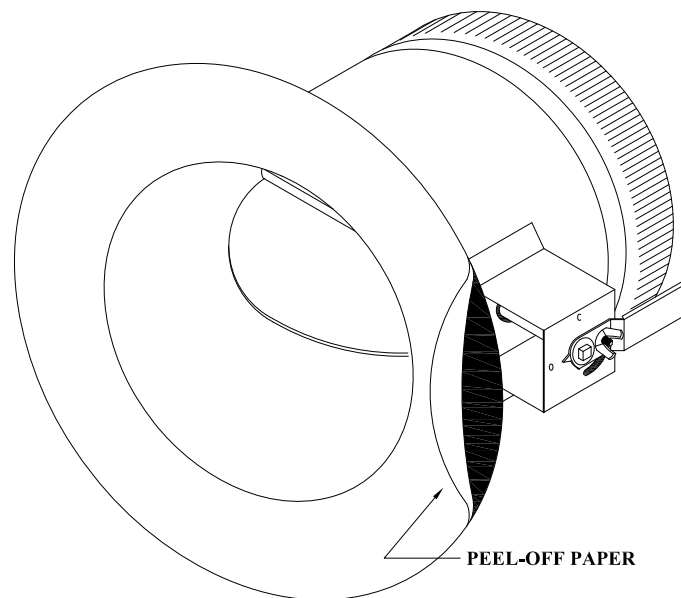

OPTIONS

No. 711: TAKE OFF WITH GASKET AND PREDRILLED
DAMPER AXIS HOLES.

No. 713: TAKE OFF WITH GASKET AND SCOOP.

No. 717: TAKEOFF WITH GASKET, SCOOP AND
MANUAL VOLUME DAMPER.

SPECIAL NOTES

RECOMMENDED INSTALLATION: DAMPER AXIS PARALLEL TO AIR FLOW.