



6390 Philips Highway  
Jacksonville, FL 32216  
Phone (904) 737-7144

## SPECIFICATION DATA SHEET

Date: 06/19/19 rev.

Drawn by: M.D.C.

## MODEL No. 714-DSO

START COLLAR WITH GASKET FLANGE,  
MANUAL VOLUME DAMPER AND  
DAMPER HANDLE STANDOFF

### DIMENSIONAL DATA

SIZES AVAILABLE: 4" THROUGH 16" DIAMETER

COLLAR LENGTH: 5 1/2"

### FABRICATION DATA

MATERIAL:  
HOT DIPPED GALVANIZED STEEL SHEET  
PER ASTM-A653 CS TYPE B.

GAUGES:  
4" THROUGH 10" = 30 GAUGE  
12" THROUGH 16" = 28 GAUGE

### FEATURES

1" WIDE FLANGE WITH GASKET MATERIAL.

MANUAL VOLUME DAMPER INSTALLED.

MANUAL VOLUME DAMPER WITH 1/4" CONTINUOUS  
ROD DAMPER AXIS WITH LOCKING REGULATOR,  
GROMMETS INSTALLED AT THE COLLAR  
PENETRATIONS.

PRE-DRILLED SCREW HOLES IN FLANGE FOR  
EASE OF INSTALLATION.

2" DAMPER HANDLE STANDOFF.

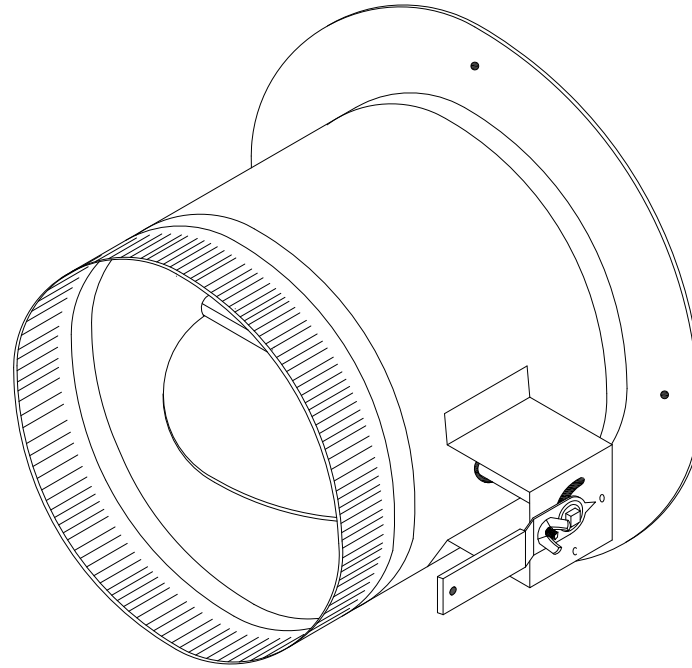

### OPTIONS

### SPECIAL NOTES

RECOMMENDED INSTALLATION: DAMPER AXIS PARALLEL TO AIR FLOW.