



6390 Philips Highway
Jacksonville, FL 32216
Phone (904) 737-7144

SPECIFICATION DATA SHEET

Date: 01/05/16

Drawn by: M.D.C.

MODEL No. 450-H

UNIVERSAL ACCESS DOOR
with HINGE

DIMENSIONAL DATA

STANDARD SIZES:

6" x 6"	14" x 14"	22" x 22"
8" x 8"	16" x 16"	24" x 24"
10" x 10"	18" x 18"	
12" x 12"	20" x 20"	

FABRICATION DATA

MATERIAL:
FABRICATED FROM HOT DIPPED GALVANIZED
STEEL SHEETS OF LOCK FORMING QUALITY
PER ASTM-A653 CS TYPE B.

DOOR CONSTRUCTION:
DOOR BODY AND FRAME = 24 GA. GALVANIZED
DOVETAILED = 26 GA. GALVANIZED

DOOR SIZES 6" X 6"- 16" X 16" ARE PROVIDED
WITH 1 CAM LOCK. LARGER DOORS HAVE
2 CAM LOCKS.

FEATURES

OUTER FLANGE IS FABRICATED WITH A
GASKET AND SCREW HOLES FOR EASY
INSTALLATION.

INNER FRAME AROUND DOOR IS FABRICATED
WITH A GASKET TO PROVIDE AN AIR TIGHT
SEAL.

DESIGNED FOR INSTALLATION IN SHEET
METAL OR 1" AND 1-1/2" DUCTBOARD.

HINGED DOOR.

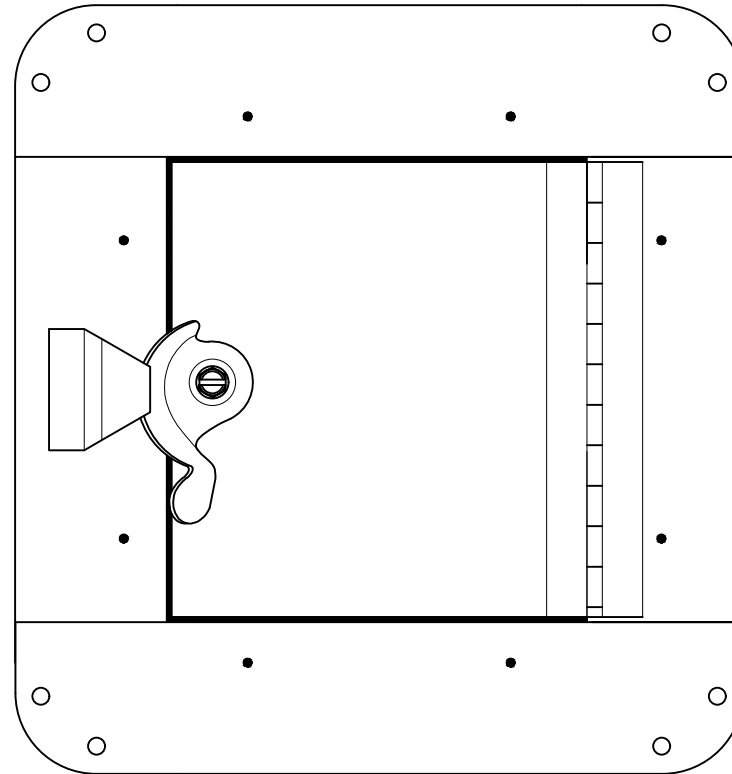

SPECIAL NOTES

OPTIONS

NON-STANDARD SIZES AVAILABLE UPON
REQUEST.