



6390 Philips Highway  
 Jacksonville, FL 32216  
 Phone (904) 737-7144

**SPECIFICATION DATA SHEET**

Date: 03/07/19 rev.

Drawn by: M.D.C.

**MODEL No. 3720-DS2**

SIZES 4" - 12" DIAMETERS  
 SPIN IN with MANUAL VOLUME DAMPER  
 and DAMPER HANDLE STANDOFF,  
 SOLID ROD DAMPER AXIS

**DIMENSIONAL DATA**

SIZES AVAILABLE: 4" THROUGH 12"

COLLAR LENGTH: 6"

**FABRICATION DATA**

MATERIAL:  
 HOT DIPPED GALVANIZED STEEL SHEET  
 PER ASTM-A653 CS TYPE B.

SIZE	BODY	DAMPER BLADE
4" - 8"	28 GA.	24 GA.
9" - 12"	26 GA.	24 GA.

**FEATURES**

FABRICATED WITH CONTINUOUS WELD  
 LONGITUDINAL SEAM FOR NO AIR LEAKAGE  
 AT 2" W.G. STATIC PRESSURE.

ALL SIZES: 3/8" CONTINUOUS ROD DAMPER AXIS  
 WITH NYLON GROMMETS INSTALLED AT  
 SLEEVE PENETRATIONS.

2" DAMPER HANDLE STANDOFF TO ALLOW  
 CLEARANCE FOR EXTERNAL INSULATION.

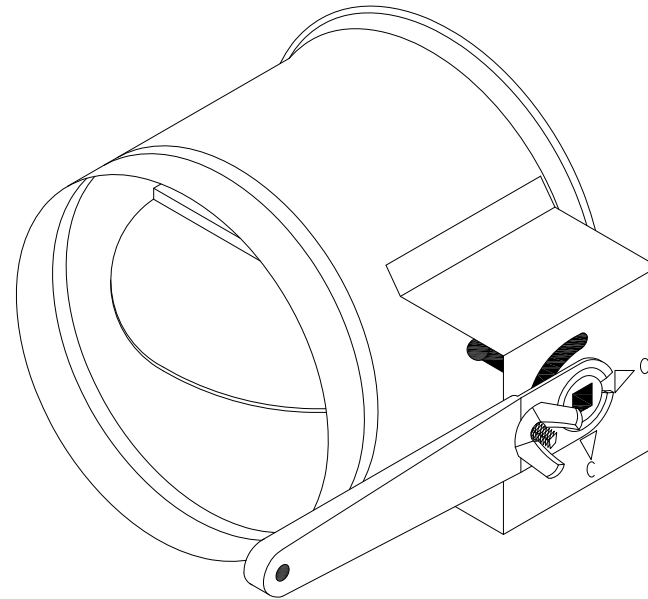

**OPTIONS**

NO. 3720: SPIN IN.

NO. 3720-D: SPIN IN WITH DAMPER

NO. 3720-DS W/ SCOOP: SPIN IN WITH DAMPER,  
 STANDOFF AND SCOOP.

**SPECIAL NOTES**

RECOMMENDED INSTALLATION: DAMPER AXIS PARALLEL TO AIR FLOW.

MADE TO MEET S.M.A.C.N.A. GAUGE STANDARDS. MAXIMUM 10" W.G. STATIC PRESSURE SCHEDULE.  
 (S.M.A.C.N.A. HVAC DUCT CONSTRUCTION STANDARDS, THIRD EDITION-2005)