



6390 Philips Highway  
 Jacksonville, FL 32216  
 Phone (904) 737-7144

**SPECIFICATION DATA SHEET**

**MODEL No. 3500**

**45 DEGREE TAKEOFF WITH GASKET FLANGE  
 FOR USE IN 1" OR 1-1/2" DUCT BOARD**

Date: 02/25/03

Drawn by: M.D.C.

**DIMENSIONAL DATA**

DIAMETER	RECT. OPENING	HEIGHT
4"	8" x 6"	11 1/2"
5"	10" x 6"	10 1/2"
6"	12" x 6"	10 1/2"
7"	12" x 6"	11 1/2"
8"	12" x 6"	10 1/2"
9"	15" x 6"	12 1/2"
10"	16" x 6 3/4"	12"
12"	18" x 8 1/2"	12"
14"	20" x 9 1/2"	12 1/2"
16"	24" x 12"	13 1/2"
18"	26" x 14"	14"
20"	28" x 16"	16"

HEIGHT DIMENSION DOES NOT INCLUDE TABS.

**FABRICATION DATA**

**MATERIAL:**  
 FABRICATED FROM HOT DIPPED GALVANIZED  
 STEEL SHEETS PER ASTM-A653 CS TYPE B.

**GAUGES:**  
 4" THROUGH 8" = 28 GAUGE  
 9" THROUGH 14" = 26 GAUGE  
 16" THROUGH 20" = 24 GAUGE

**FEATURES**

CONTINUOUS WELD LONGITUDINAL SEAM  
 FOR NO AIR LEAKAGE AT 2" W.G. STATIC  
 PRESSURE.

1" WIDE FLANGE WITH GASKET.

DOVETAIL TABS FOR 1" & 1-1/2" DUCT BOARD.

5 3/8" LONG COLLAR.

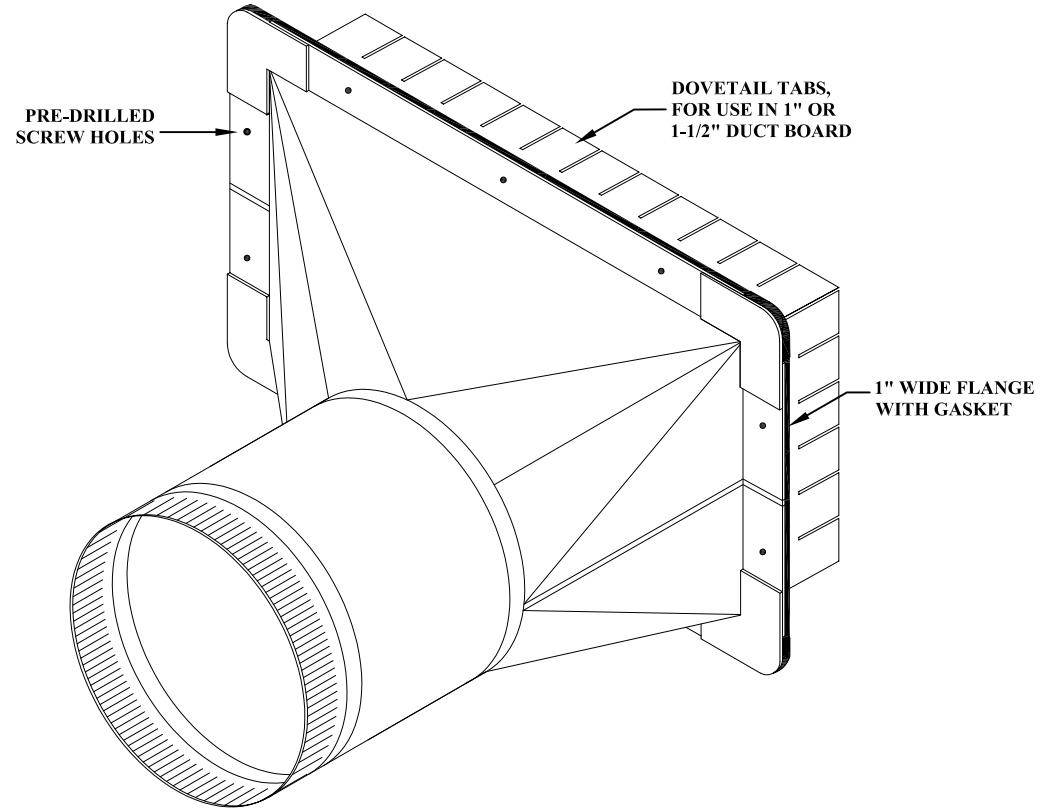

**SPECIAL NOTES**

MADE TO MEET S.M.A.C.N.A. GAUGE STANDARDS. MAXIMUM 2" W.G. STATIC PRESSURE SCHEDULE.  
 (S.M.A.C.N.A. HVAC DUCT CONSTRUCTION STANDARDS, SECOND EDITION - 1995)