



6390 Philips Highway
 Jacksonville, FL 32216
 Phone (904) 737-7144

SPECIFICATION DATA SHEET

Date: 04/18/23 rev. Drawn by: J.E.P.

MODEL No. 349-SD

SIDEWALL VENT with SCREEN and DAMPER

DIMENSIONAL DATA

PIPE SIZE	DIMENSION		
	A	B	C
3"	3"	5"	7"
4"	3"	5"	7"
5"	3"	7"	9"
6"	3"	7"	9"
7"	5"	9"	11"
8"	5"	9"	11"
9"	5"	9"	11"
10"	7-1/4"	12"	14"
12"	7-1/4"	12"	14"

COLLAR LENGTH = 5-3/4" (ALL SIZES)

FABRICATION DATA

MATERIAL:
 FABRICATED FROM HOT DIPPED GALVANIZED STEEL SHEETS PER ASTM-A653 CS TYPE B.

GAUGES:
 3" THROUGH 9" = 28 GAUGE
 10" THROUGH 12" = 26 GAUGE

FEATURES

1/2" FLANGE TURNED IN AT VENT OPENING.
 1/2" HARDWARE CLOTH WELDED OVER VENT OPENING.
 FLAPPER DAMPER INSTALLED.

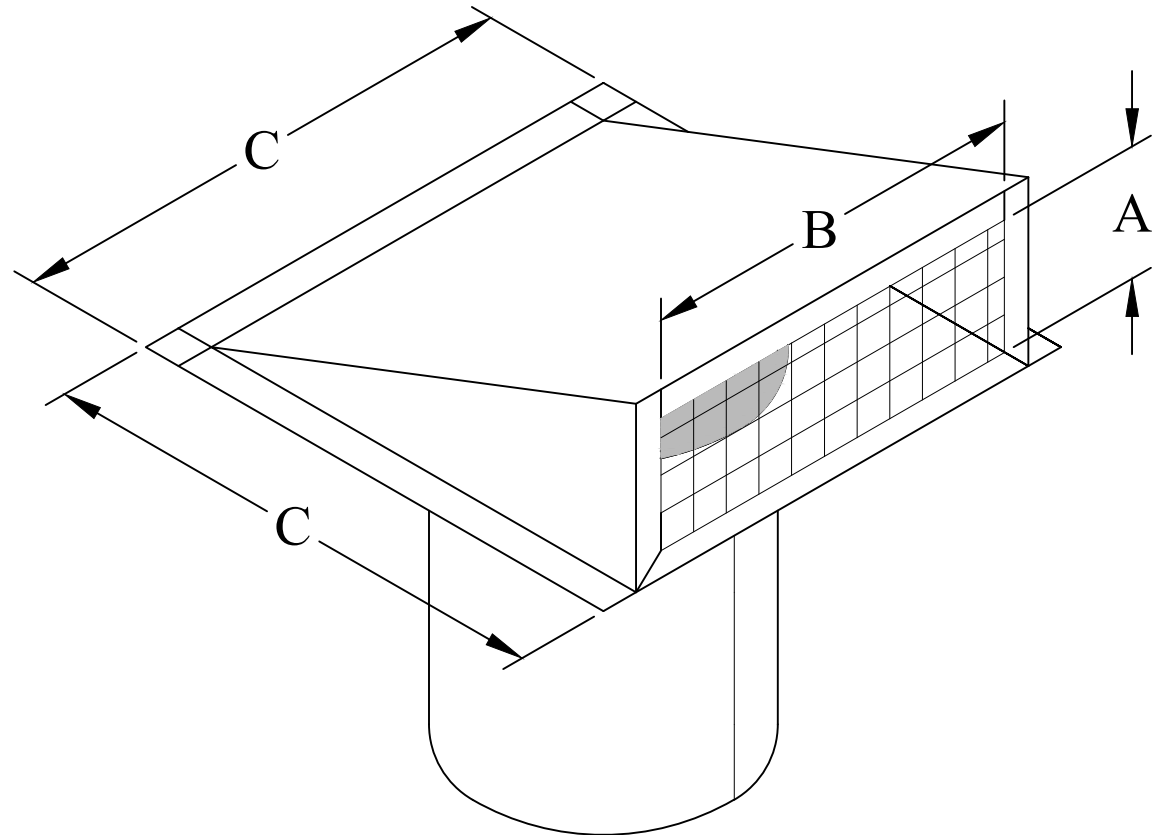

OPTIONS

SPECIAL NOTES