



6390 Philips Highway  
Jacksonville, FL 32216  
Phone (904) 737-7144

## SPECIFICATION DATA SHEET

## MODEL No. 3400-DS2

SIZES 4" - 12" DIAMETERS  
CENTER TAPER TAKEOFF with GASKET FLANGE,  
MANUAL VOLUME DAMPER with HANDLE STANDOFF  
SOLID ROD DAMPER AXIS

Date: 07/26/12 rev.

Drawn by: M.D.C.

### DIMENSIONAL DATA

DIAMETER	RECT. OPENING	HEIGHT
4"	8" x 6"	11 1/2"
5"	10" x 6"	10 1/2"
6"	12" x 6"	10 1/2"
7"	12" x 6"	11 1/2"
8"	12" x 6"	10 1/2"
9"	15" x 6"	12 1/2"
10"	16" x 6 3/4"	12"
12"	18" x 8 1/2"	12"

### FABRICATION DATA

MATERIAL:  
HOT DIPPED GALVANIZED STEEL SHEET  
PER ASTM-A653 CS TYPE B.

SIZE	BODY	DAMPER BLADE
4" - 8"	28 GA.	24 GA.
9" - 12"	26 GA.	24 GA.

### FEATURES

CONTINUOUS WELD LONGITUDINAL SEAM  
FOR NO AIR LEAKAGE AT 2" W.G. STATIC  
PRESSURE.

1" WIDE FLANGE WITH GASKET AND  
PRE-DRILLED SCREW HOLES FOR EASE OF  
INSTALLATION.

5 3/8" LONG COLLAR.

SIZES 4" THROUGH 12": 3/8" CONTINUOUS ROD  
DAMPER AXIS WITH LOCKING REGULATOR,  
NYLON GROMMETS INSTALLED AT THE  
COLLAR PENETRATIONS.

2" DAMPER HANDLE STANDOFF.

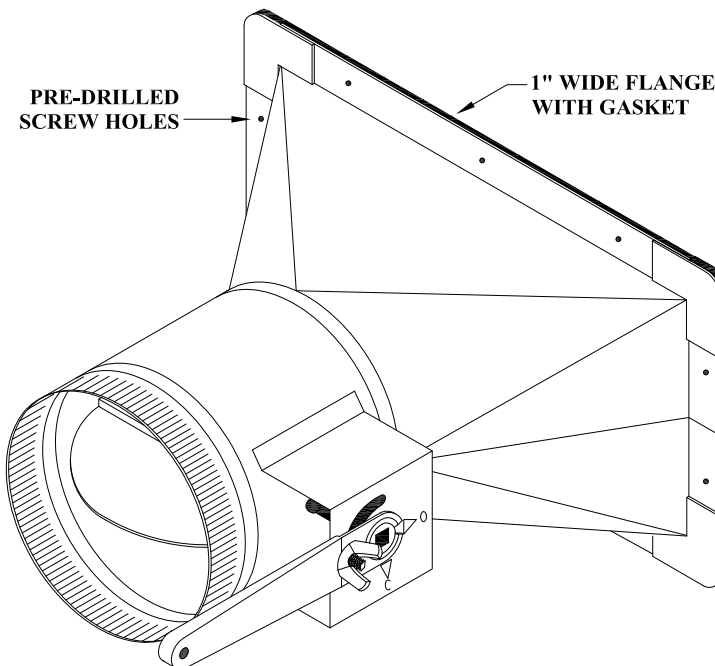

### SPECIAL NOTES

RECOMMENDED INSTALLATION: DAMPER AXIS PARALLEL TO AIR FLOW.

MADE TO MEET S.M.A.C.N.A. GAUGE STANDARDS. MAXIMUM 2" W.G. STATIC PRESSURE SCHEDULE.  
(S.M.A.C.N.A. HVAC DUCT CONSTRUCTION STANDARDS, SECOND EDITION-1995)