



6390 Philips Highway
Jacksonville, FL 32216
Phone (904) 737-7144

SPECIFICATION DATA SHEET

Date: 07/26/12 rev.

Drawn by: M.D.C.

MODEL No. 3310-DS2

SIZES 6" - 12" DIAMETERS
TAKEOFF COLLAR FOR ROUND PIPE WITH GASKET
FLANGE, MANUAL VOLUME DAMPER WITH HANDLE
STANDOFF, SOLID ROD DAMPER AXIS

DIMENSIONAL DATA

SIZES AVAILABLE: 6" THROUGH 12"

COLLAR LENGTH: 6"

1- 1/2" WIDE FLANGE.

FABRICATION DATA

MATERIAL:
FABRICATED FROM HOT DIPPED GALVANIZED
STEEL SHEETS PER ASTM-A653 CS TYPE B.

SIZE	BODY	DAMPER BLADE
6" - 8"	28 GA.	24 GA.
9" - 12"	26 GA.	24 GA.

FEATURES

CONTINUOUS WELD LONGITUDINAL SEAM
FOR NO AIR LEAKAGE AT 2" W.G. STATIC
PRESSURE.

FLANGE WITH GASKET AND PRE-DRILLED SCREW
HOLES FOR EASE OF INSTALLATION.

DAMPER TO HAVE A 3/8" SQUARE CONTINUOUS
ROD AXIS WITH LOCKING REGULATOR, NYLON
GROMMETS INSTALLED AT THE COLLAR
PENETRATIONS.

2" DAMPER HANDLE STANDOFF.

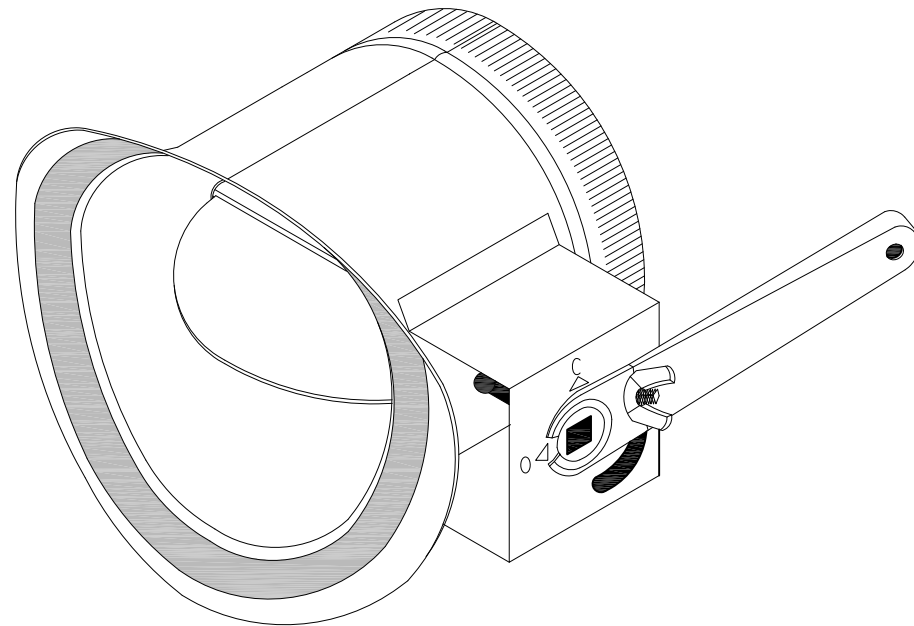

SPECIAL NOTES

RECOMMENDED INSTALLATION: DAMPER AXIS PARALLEL TO AIR FLOW.

MADE TO MEET S.M.A.C.N.A. GAUGE STANDARDS. MAXIMUM 2" W.G. STATIC PRESSURE SCHEDULE.
(S.M.A.C.N.A. HVAC DUCT CONSTRUCTION STANDARDS, SECOND EDITION-1995)