



6390 Philips Highway
Jacksonville, FL 32216
Phone (904) 737-7144

SPECIFICATION DATA SHEET

Date: 03/06/19 rev.

Drawn by: M.D.C.

MODEL No. 3305-DS2

SIZES 4" - 12" DIAMETERS
45° TAKEOFF FOR ROUND PIPE WITH GASKET FLANGE
AND MANUAL VOLUME DAMPER, SOLD ROD
DAMPER AXIS WITH DAMPER HANDLE STANDOFF

DIMENSIONAL DATA

BRANCH DUCT DIAMETER	APPROX. TRUNK OPENING
6"	12" x 6"
7"	13" x 7"
8"	14" x 8"
9"	15" x 9"
10"	16" x 10"
12"	18" x 12"

FABRICATION DATA

MATERIAL:
HOT DIPPED GALVANIZED STEEL SHEET
PER ASTM-A653 CS TYPE B.

SIZE	BODY	DAMPER BLADE
6" - 8"	28 GA.	24 GA.
9" - 12"	26 GA.	24 GA.

FEATURES

CONTINUOUS WELD LONGITUDINAL SEAM
FOR NO AIR LEAKAGE AT 2" W.G. STATIC
PRESSURE.

1" WIDE FLANGE WITH GASKET CONTOURED TO
FIT ROUND TRUNK DUCT.

5 3/8" LONG COLLAR.

SIZES 6" THROUGH 12": 3/8" CONTINUOUS ROD
DAMPER AXIS WITH LOCKING REGULATOR,
NYLON GROMMETS INSTALLED AT THE
COLLAR PENETRATIONS.

2" DAMPER HANDLE STANDOFF.

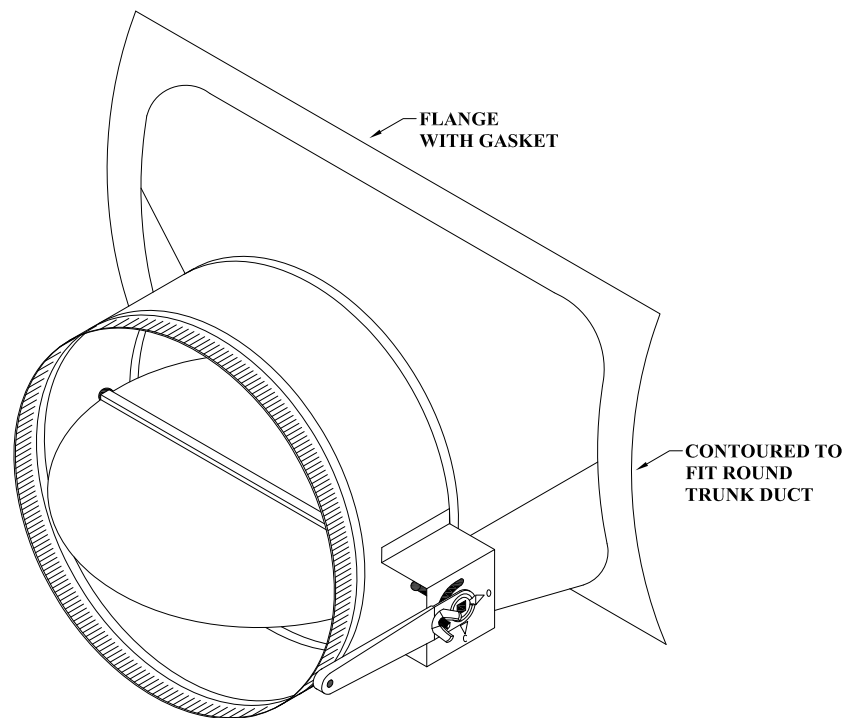

SPECIAL NOTES

RECOMMENDED INSTALLATION: DAMPER AXIS PARALLEL TO AIR FLOW.

MADE TO MEET S.M.A.C.N.A. GAUGE STANDARDS. MAXIMUM 10" W.G. STATIC PRESSURE SCHEDULE.
(S.M.A.C.N.A. HVAC DUCT CONSTRUCTION STANDARDS, THIRD EDITION-2005)

ORDER BY BRANCH DUCT DIAMETER.
PLEASE NOTE TRUNK DUCT SIZE WHEN ORDERING.