



6390 Philips Highway
Jacksonville, FL 32216
Phone (904) 737-7144

SPECIFICATION DATA SHEET

Date: 11/12/19 rev.

Drawn by: M.D.C.

MODEL No. 3305-DS

45° TAKEOFF FOR ROUND PIPE WITH GASKET FLANGE
AND MANUAL VOLUME DAMPER WITH DAMPER
HANDLE STANDOFF

DIMENSIONAL DATA

| BRANCH DUCT DIAMETER | APPROX. TRUNK OPENING |
|-------------------------|--------------------------|
| 6" | 12" x 6" |
| 7" | 13" x 7" |
| 8" | 14" x 8" |
| 9" | 15" x 9" |
| 10" | 16" x 10" |
| 12" | 18" x 12" |
| 14" | 20" x 14" |
| 16" | 22" x 16" |
| 18" | 24" x 18" |
| 20" | 26" x 20" |

FABRICATION DATA

MATERIAL:
HOT DIPPED GALVANIZED STEEL SHEET
PER ASTM-A653 CS TYPE B.

| SIZE | BODY | DAMPER BLADE |
|-----------|--------|--------------|
| 6" - 8" | 28 GA. | 24 GA. |
| 9" - 14" | 26 GA. | 24 GA. |
| 16" - 20" | 24 GA. | 22 GA. |

FEATURES

CONTINUOUS WELD LONGITUDINAL SEAM
FOR NO AIR LEAKAGE AT 2" W.G. STATIC
PRESSURE.

1" WIDE FLANGE WITH GASKET CONTOURED TO
FIT ROUND TRUNK DUCT.

5 3/8" LONG COLLAR.

SIZES 6" THROUGH 12" HAVE MANUAL VOLUME
DAMPER WITH 1/4" CONTINUOUS ROD DAMPER
AXIS WITH LOCKING REGULATOR, GROMMETS
INSTALLED AT THE COLLAR PENETRATIONS.

SIZES 14" THROUGH 20" HAVE 3/8" CONTINUOUS
ROD DAMPER AXIS WITH LOCKING REGULATOR,
NYLON GROMMETS INSTALLED AT THE
COLLAR PENETRATIONS.

2" DAMPER HANDLE STANDOFF.

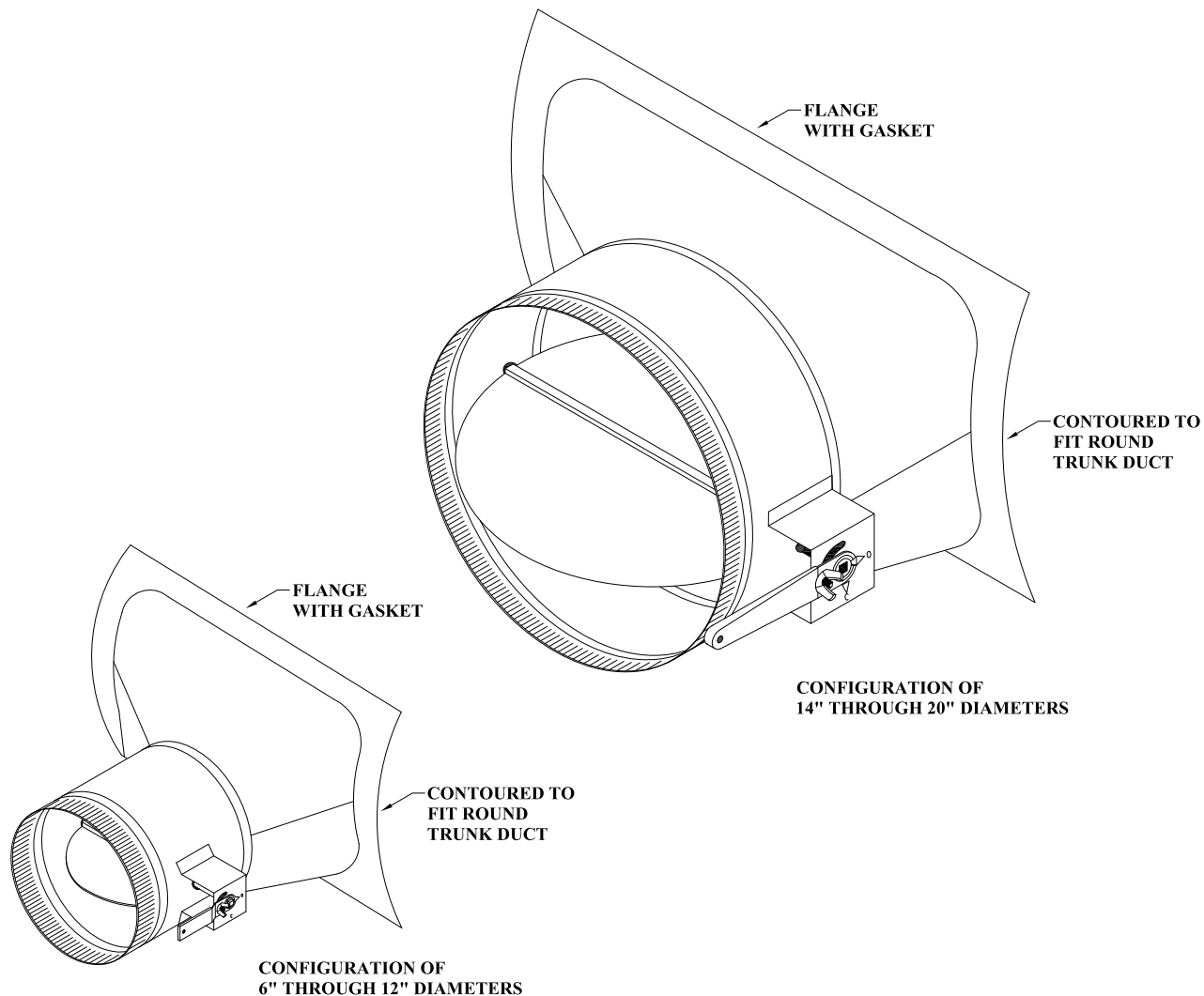

SPECIAL NOTES

RECOMMENDED INSTALLATION: DAMPER AXIS PARALLEL TO AIR FLOW.

MADE TO MEET S.M.A.C.N.A. GAUGE STANDARDS. MAXIMUM 10" W.G. STATIC PRESSURE SCHEDULE.
(S.M.A.C.N.A. HVAC DUCT CONSTRUCTION STANDARDS, THIRD EDITION-2005)

ORDER BY BRANCH DUCT DIAMETER.
PLEASE NOTE TRUNK DUCT SIZE WHEN ORDERING.