



6390 Philips Highway
Jacksonville, FL 32216
Phone (904) 737-7144

SPECIFICATION DATA SHEET

MODEL No. 3212-DS2

CONICAL TAKEOFF
FOR ROUND TRUNK DUCT WITH MANUAL
VOLUME DAMPER AND STANDOFF

Date: 09/11/13

Drawn by: M.D.C.

DIMENSIONAL DATA

SIZES AVAILABLE: 4" THROUGH 20"

CONICAL CONNECTION HOLE TO TRUNK DUCT
IS APPROXIMATELY 2" GREATER THAN
BRANCH DUCT DIMENSION.

5 3/8" LONG COLLAR.

FABRICATION DATA

MATERIAL:
FABRICATED FROM HOT DIPPED GALVANIZED
STEEL SHEETS PER ASTM-A653 CS TYPE B.

GAUGES:

4" THROUGH 8" = 28 GAUGE

9" THROUGH 14" = 26 GAUGE

16" THROUGH 20" = 24 GAUGE

FEATURES

CONTINUOUS WELD LONGITUDINAL SEAM
FOR NO AIR LEAKAGE AT 2" W.G. STATIC
PRESSURE.

1" WIDE FLANGE WITH GASKET AND
PRE-DRILLED SCREW HOLES FOR EASE OF
INSTALLATION.

ALL SIZES: 3/8" CONTINUOUS ROD DAMPER
AXIS WITH LOCKING REGULATOR, NYLON
GROMMETS INSTALLED AT THE COLLAR
PENETRATIONS.

2" DAMPER HANDLE STANDOFF.

TAKEOFF CONTOURED TO MATCH RADIUS OF
TRUNK DUCT.

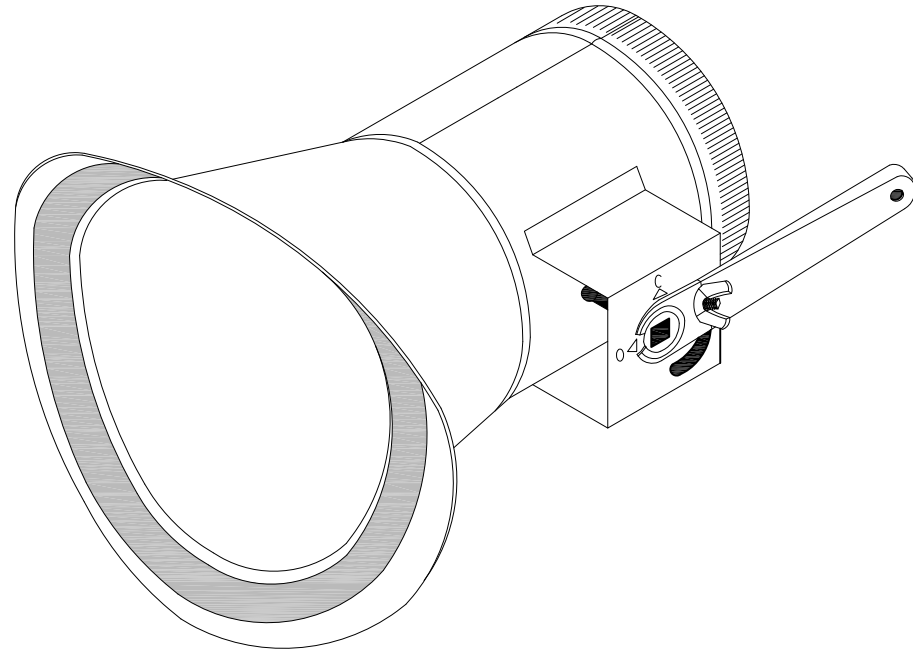

SPECIAL NOTES

RECOMMENDED INSTALLATION: DAMPER AXIS PARALLEL TO AIR FLOW.

MADE TO MEET S.M.A.C.N.A. GAUGE STANDARDS. MAXIMUM 2" W.G. STATIC PRESSURE SCHEDULE.
(S.M.A.C.N.A. HVAC DUCT CONSTRUCTION STANDARDS, SECOND EDITION-1995)

NOTE BRANCH DUCT DIMENSION WHEN ORDERING.