



6390 Philips Highway
 Jacksonville, FL 32216
 Phone (904) 737-7144

SPECIFICATION DATA SHEET

MODEL No. 3212-DS

**CONICAL TAKEOFF
 FOR ROUND TRUNK DUCT
 WITH MANUAL VOLUME DAMPER AND STANDOFF**

Date: 06/10/20 rev.

Drawn by: M.D.C.

DIMENSIONAL DATA

SIZES AVAILABLE: 4" THROUGH 20"

CONICAL CONNECTION HOLE TO TRUNK DUCT IS APPROXIMATELY 2" GREATER THAN BRANCH DUCT DIMENSION.

5 3/8" LONG COLLAR.

FABRICATION DATA

MATERIAL:
 FABRICATED FROM HOT DIPPED GALVANIZED STEEL SHEETS PER ASTM-A653 CS TYPE B.

SIZE	BODY	DAMPER BLADE
4" - 8"	28 GA.	24 GA.
9" - 14"	26 GA.	24 GA.
16" - 20"	24 GA.	22 GA.

FEATURES

CONTINUOUS WELD LONGITUDINAL SEAM FOR NO AIR LEAKAGE AT 2" W.G. STATIC PRESSURE.

1" WIDE FLANGE WITH GASKET AND PRE-DRILLED SCREW HOLES FOR EASE OF INSTALLATION.

SIZES 4" THROUGH 12" HAVE MANUAL VOLUME DAMPER WITH 1/4" CONTINUOUS ROD DAMPER AXIS WITH LOCKING REGULATOR, GROMMETS INSTALLED AT THE COLLAR PENETRATIONS.

SIZES 14" THROUGH 20": 3/8" CONTINUOUS ROD DAMPER AXIS WITH LOCKING REGULATOR, NYLON GROMMETS INSTALLED AT THE COLLAR PENETRATIONS.

2" DAMPER HANDLE STANDOFF.

TAKEOFF CONTOURED TO MATCH RADIUS OF TRUNK DUCT.

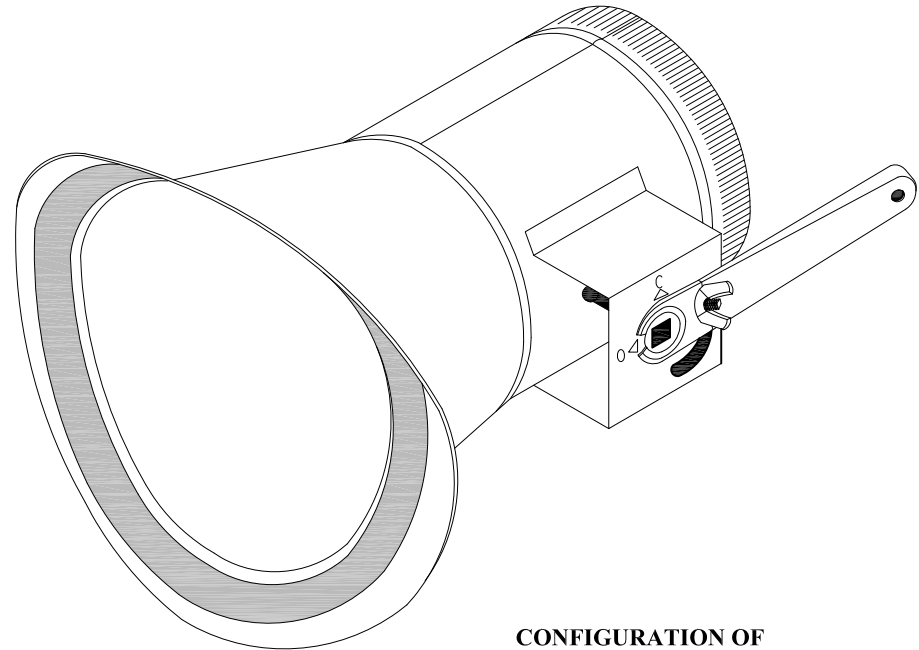

**CONFIGURATION OF
 14" THROUGH 20" DIAMETERS**

SPECIAL NOTES

RECOMMENDED INSTALLATION: DAMPER AXIS PARALLEL TO AIR FLOW.

MADE TO MEET S.M.A.C.N.A. GAUGE STANDARDS. MAXIMUM 2" W.G. STATIC PRESSURE SCHEDULE. (S.M.A.C.N.A. HVAC DUCT CONSTRUCTION STANDARDS, SECOND EDITION-1995)

NOTE BRANCH DUCT DIMENSION WHEN ORDERING.