



6390 Philips Highway
 Jacksonville, FL 32216
 Phone (904) 737-7144

SPECIFICATION DATA SHEET

Date: 07/26/12 rev.

Drawn by: M.D.C.

MODEL No. 3211-DS2

SIZES 4" - 12" DIAMETERS
 CONICAL TAKEOFF WITH INSULATION GUARD,
 MANUAL VOLUME DAMPER WITH HANDLE STANDOFF,
 SOLID ROD DAMPER AXIS

DIMENSIONAL DATA

SIZES AVAILABLE: 4" THROUGH 12" DIAMETER
 CONICAL CONNECTION HOLE TO TRUNK DUCT
 IS APPROXIMATELY 2" GREATER THAN
 BRANCH DUCT DIMENSION.

FABRICATION DATA

MATERIAL:
 FABRICATED FROM HOT DIPPED GALVANIZED
 STEEL SHEETS PER ASTM-A653 CS TYPE B.

| SIZE | BODY | DAMPER BLADE |
|----------|--------|--------------|
| 4" - 8" | 28 GA. | 24 GA. |
| 9" - 12" | 26 GA. | 24 GA. |

FEATURES

CONTINUOUS WELD LONGITUDINAL SEAM FOR
 NO AIR LEAKAGE @ 2" W.G. STATIC PRESSURE.
 1" WIDE FLANGE WITH GASKET
 5 3/8" LONG COLLAR.
 SIZES 4" THROUGH 12": 3/8" CONTINUOUS ROD
 DAMPER AXIS WITH LOCKING REGULATOR,
 NYLON GROMMETS INSTALLED AT THE
 COLLAR PENETRATIONS.
 2" DAMPER HANDLE STANDOFF.

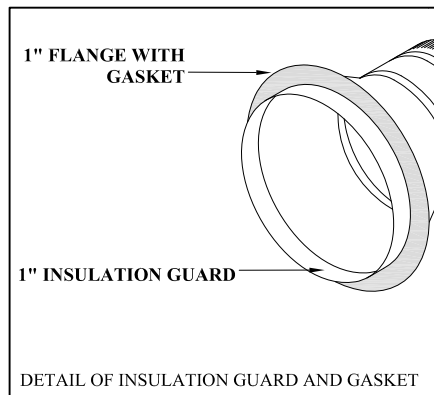
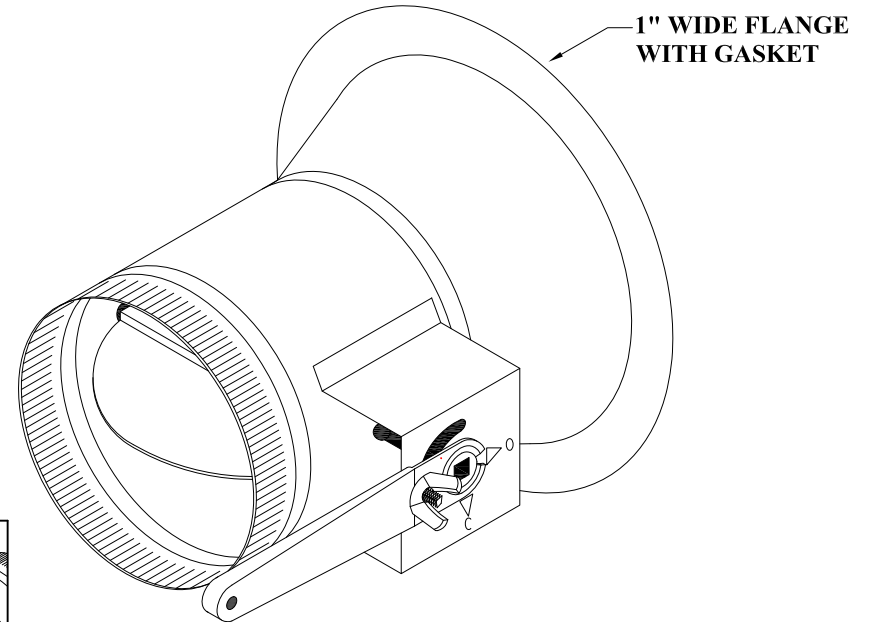

OPTIONS

SPECIAL NOTES

RECOMMENDED INSTALLATION: DAMPER AXIS PARALLEL TO AIR FLOW.
 MADE TO MEET S.M.A.C.N.A. GAUGE STANDARDS. MAXIMUM 2" W.G. STATIC PRESSURE SCHEDULE.
 (S.M.A.C.N.A. HVAC DUCT CONSTRUCTION STANDARDS, SECOND EDITION-1995)

NOTE BRANCH DUCT DIMENSION WHEN ORDERING.