



6390 Philips Highway
Jacksonville, FL 32216
Phone (904) 737-7144

SPECIFICATION DATA SHEET

Date: 03/05/19 rev.

Drawn by: M.D.C.

MODEL No. 3210-DS2

SIZES 4" - 12" DIAMETERS
CONICAL TAKEOFF WITH GASKET RING,
MANUAL VOLUME DAMPER WITH HANDLE STANDOFF,
SOLID ROD DAMPER AXIS

DIMENSIONAL DATA

SIZES AVAILABLE: 4" THROUGH 12" DIAMETER
ORDER BY BRANCH DUCT DIMENSION.
HOLE DIMENSION CUT IN TRUNK DUCT IS
2" GREATER THAN BRANCH DUCT.

FABRICATION DATA

MATERIAL:
FABRICATED FROM HOT DIPPED GALVANIZED
STEEL SHEETS PER ASTM-A653 CS TYPE B.

SIZE	BODY	DAMPER BLADE
4" - 8"	28 GA.	24 GA.
9" - 12"	26 GA.	24 GA.

FEATURES

CONTINUOUS WELD LONGITUDINAL SEAM
FOR NO AIR LEAKAGE AT 2" W.G. STATIC
PRESSURE.
1" WIDE FLANGE WITH GASKET AND
PRE-DRILLED SCREW HOLES FOR EASE OF
INSTALLATION.
5 3/8" LONG COLLAR.
SIZES 4" THROUGH 12": 3/8" CONTINUOUS ROD
DAMPER AXIS WITH LOCKING REGULATOR,
NYLON GROMMETS INSTALLED AT THE
COLLAR PENETRATIONS.
2" DAMPER HANDLE STANDOFF.

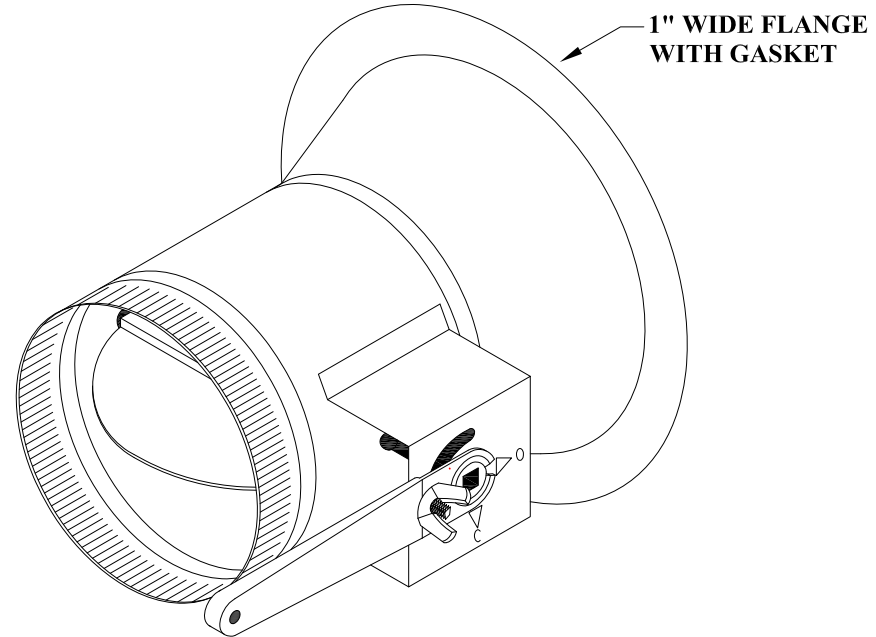

OPTIONS

- No. 3210: CONICAL TAKEOFF
- No. 3210-D: CONICAL TAKEOFF WITH MANUAL
VOLUME DAMPER
- No. 3210-DS: CONICAL TAKEOFF WITH MANUAL
VOLUME DAMPER AND STANDOFF

SPECIAL NOTES

RECOMMENDED INSTALLATION: DAMPER AXIS PARALLEL TO AIR FLOW.
MADE TO MEET S.M.A.C.N.A. GAUGE STANDARDS. MAXIMUM 10" W.G. STATIC PRESSURE SCHEDULE.
(S.M.A.C.N.A. HVAC DUCT CONSTRUCTION STANDARDS, THIRD EDITION-2005)
AVAILABLE: SIZES 4" - 8" FABRICATED FROM 26 GAUGE GALVANIZED STEEL (SPECIAL ORDER).