



6390 Philips Highway
 Jacksonville, FL 32216
 Phone (904) 737-7144

SPECIFICATION DATA SHEET

MODEL No. 317-DSO

**TAKE OFF COLLAR FOR ROUND PIPE
 WITH PEEL OFF GASKET, MANUAL VOLUME DAMPER,
 DAMPER HANDLE STANDOFF AND SCOOP**

Date: 05/20/20 rev.

Drawn by: M.D.C.

DIMENSIONAL DATA

DIAMETER	TO FIT PIPE SIZE
4"	8"
5"	9"-10"
6"	10"-12"
7"	10"-12"
8"	12"-14"
9"	12"-14"
10"	14"-16"
12"	16"-18"
14"	18"-20"
16"	20"

FABRICATION DATA

MATERIAL:
 HOT DIPPED GALVANIZED STEEL SHEET
 PER ASTM-A653 CS TYPE B.

GAUGES:
 4" THROUGH 9" = 30 GAUGE
 10" THROUGH 16" = 28 GAUGE

FEATURES

1 1/2" WIDE CONTOURED FLANGE WITH GASKET
 DESIGNED TO MOUNT ON ROUND PIPE.
 CRIMPED MALE CONNECTION FOR BRANCH DUCT.
 GASKET HAS PEEL-OFF PAPER.
 SCOOP PENETRATES INTO TRUNK DUCT AIR
 STREAM.
 MANUAL VOLUME DAMPER INSTALLED.
 2" DAMPER HANDLE STANDOFF.

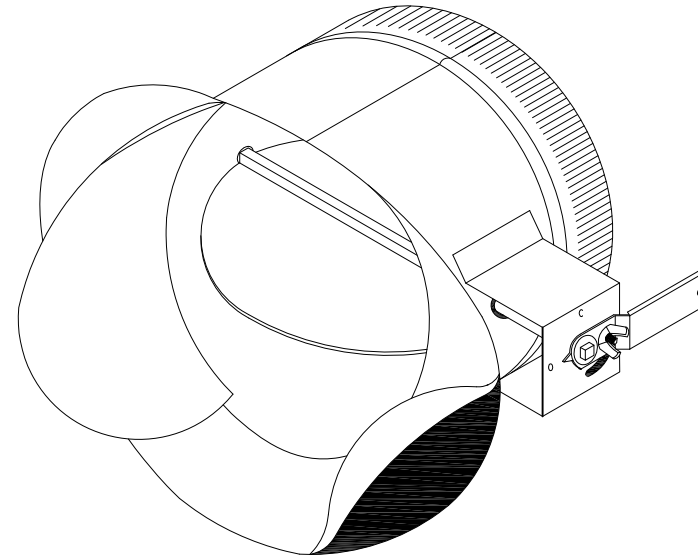

OPTIONS

No. 311: TAKE OFF FOR PIPE WITH GASKET
 No. 313: TAKEOFF FOR PIPE WITH GASKET AND
 SCOOP.
 No. 317: TAKEOFF FOR PIPE WITH GASKET, SCOOP
 AND MANUAL VOLUME DAMPER.

SPECIAL NOTES

RECOMMENDED INSTALLATION: DAMPER AXIS PARALLEL TO AIR FLOW.
 MANUAL VOLUME DAMPER WITH 1/4" CONTINUOUS ROD DAMPER AXIS WITH LOCKING REGULATOR,
 GROMMETS INSTALLED AT THE COLLAR PENETRATIONS.