



6390 Philips Highway
Jacksonville, FL 32216
Phone (904) 737-7144

SPECIFICATION DATA SHEET

Date: 10/12/20 rev.

Drawn by: J.E.P.

MODEL No. 314-DSO

TAKE OFF COLLAR FOR ROUND PIPE WITH
GASKETED FLANGE, MANUAL VOLUME,
DAMPER AND DAMPER HANDLE STANDOFF

DIMENSIONAL DATA

DIAMETER	TO FIT PIPE SIZE
4"	8"
5"	9"-10"
6"	10"-12"
7"	10"-12"
8"	12"-14"
9"	12"-14"
10"	14"-16"
12"	16"-18"
14"	18"-20"
16"	20"

FABRICATION DATA

MATERIAL:
HOT DIPPED GALVANIZED STEEL SHEET
PER ASTM-A653 CS TYPE B.

GAUGES:
4" THROUGH 9" = 30 GAUGE
10" THROUGH 16" = 28 GAUGE

FEATURES

CONTOURED FLANGE WITH 1/2" WIDE
GASKET DESIGNED TO MOUNT
TO ROUND PIPE.

CRIMPED MALE CONNECTION FOR BRANCH DUCT.
MANUAL VOLUME DAMPER INSTALLED.

SIZES 4" THROUGH 10" HAVE DAMPER WITH 1/4"
REGULATOR.

SIZES 12" THROUGH 16" HAVE REINFORCED
DAMPER AXIS WITH 1/4" REGULATOR, END
BEARING WITH WASHER AND WING NUT.
2" DAMPER HANDLE STANDOFF.

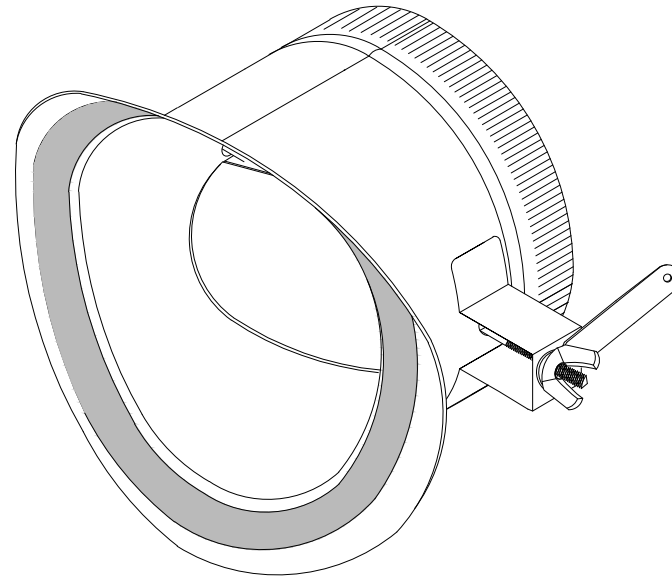

SPECIAL NOTES

RECOMMENDED INSTALLATION: DAMPER AXIS PARALLEL TO AIR FLOW.