



6390 Philips Highway  
Jacksonville, FL 32216  
Phone (904) 737-7144

## SPECIFICATION DATA SHEET

Date: 02/07/08

Drawn by: DON.JR.

## MODEL No. 1793

SLANT TOP REGISTER BOX  
with COLLAR INSTALLED  
R-8.0 INTERNAL INSULATION

### DIMENSIONAL DATA

OUTER BOX DIMENSION IS 4" GREATER THAN REGISTER DIMENSION.

3" LONG COLLAR WITH CONVEX BEAD.

### FABRICATION DATA

FABRICATED FROM 30 GAUGE GALVANIZED STEEL.

INTERNALLY INSULATED WITH R-8 INSULATION.

### FEATURES

90° OUTBOARD FLANGE WITH SOLID CORNERS.

1/2" DRYWALL FLANGE.

BLACK INTERIOR.

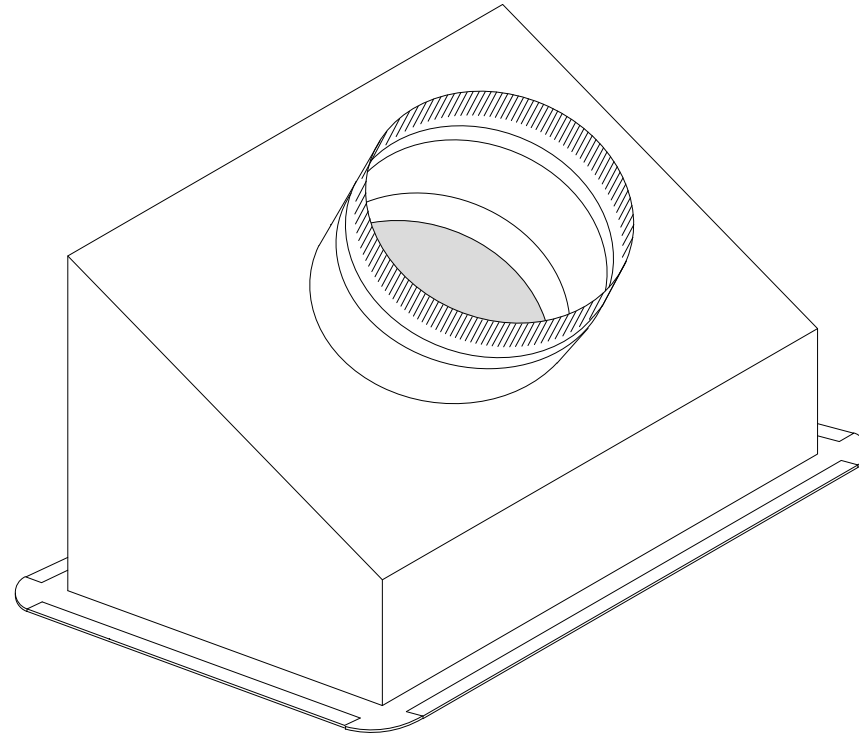

### OPTIONS

### SPECIAL NOTES

INTERNAL INSULATION USED MEETS THE REQUIREMENTS OF ASTM C 1338 (FORMERLY ASTM C 665) STANDARD TEST METHOD FOR FUNGI RESISTANCE.