



6390 Philips Highway
Jacksonville, FL 32216
Phone (904) 737-7144

SPECIFICATION DATA SHEET

MODEL No. 1292-FLG

DUCT BOARD BOX, R-6.0
WITH THERMA SEAL GASKET

Date: 04/17/12

Drawn by: M.D.C.

DIMENSIONAL DATA

11" HIGH OUTER FRAMED BOX

OUTER BOX DIMENSION IS 3" GREATER THAN REGISTER DIMENSION.

FABRICATION DATA

OUTER FRAME FABRICATED FROM 30 GAUGE GALVANIZED STEEL.

DUCT BOARD TOP AND SIDES.

FEATURES

R-6.0 INSULATION.

SOLID CORNERS WITH HANGER HOLES.

1/2" DRYWALL FLANGE.

HOLE CLUSTER FOR REGISTER ATTACHMENT.

DUCT BOARD TOP AND SIDES ALLOW FOR VARIOUS COLLAR INLET SIZES.

BLACK INTERIOR.

GASKET AROUND REGISTER OPENING SEALS BOX WHERE IT PENETRATES BUILDING ENVELOPE.

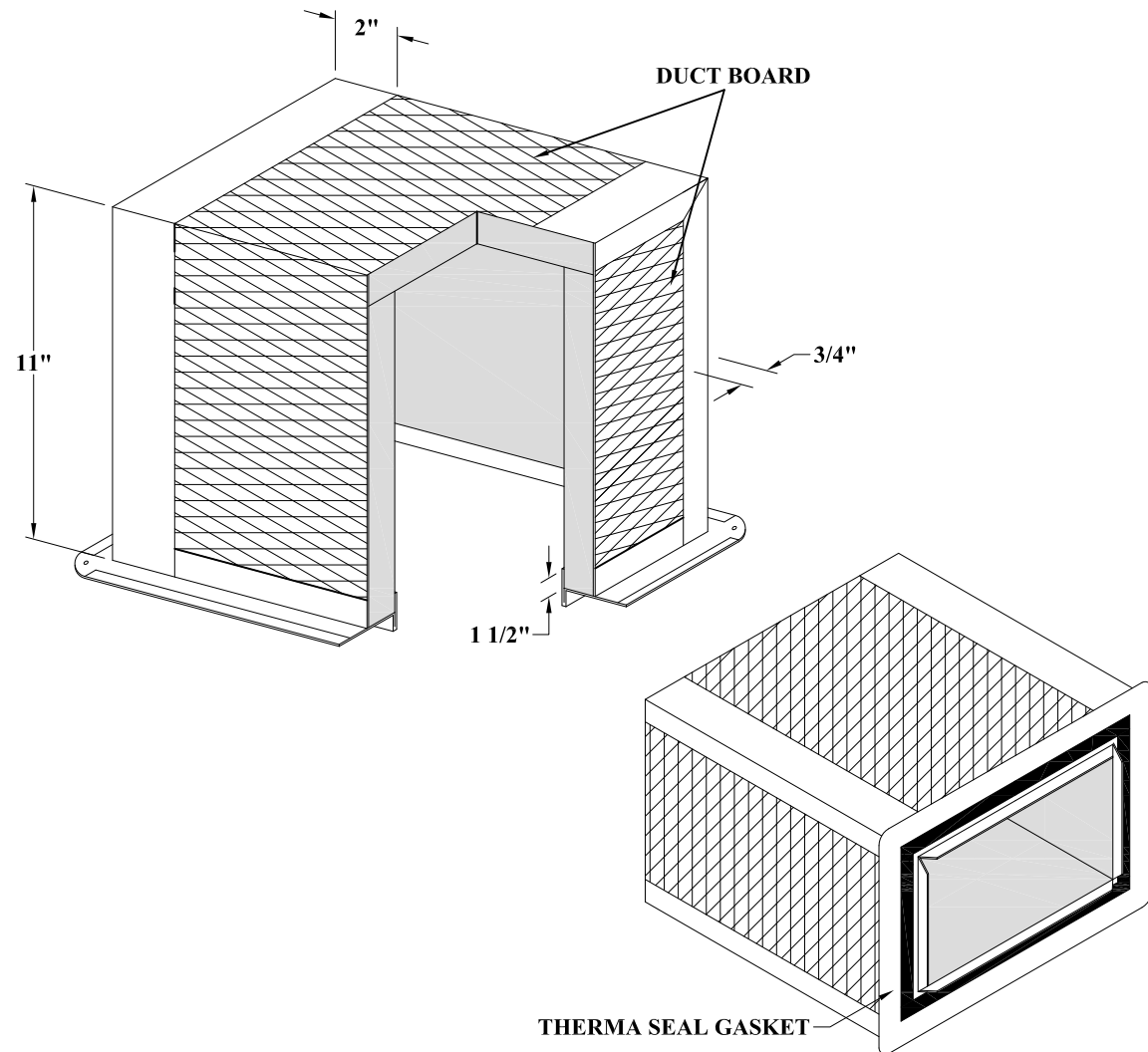

OPTIONS

No. 1292 DUCT BOARD BOX, R-4.2 INSULATION, BLACK INTERIOR.

SPECIAL NOTES

THE 2" FRAME WIDTH IS LOCATED ON THE LONGER SIDE OF THE RECTANGULAR BOX.

INTERNAL INSULATION USED MEETS THE REQUIREMENTS OF ASTM C 1338 (FORMERLY ASTM C 665) STANDARD TEST METHOD FOR FUNGI RESISTANCE.

GASKET TESTED TO ASTM E-84-91. FLAME SPREAD LESS THAN 25, SMOKE DENSITY LESS THAN 50.