



6390 Philips Highway
Jacksonville, FL 32216
Phone (904) 737-7144

SPECIFICATION DATA SHEET

Date: 05/22/03 rev. Drawn by: M.D.C.

MODEL No. 1269-FL

INSULATED REGISTER BOX

DIMENSIONAL DATA

OUTSIDE DIMENSION OF BOX = REGISTER SIZE PLUS 3".

HEIGHT OF BOX = DIAMETER OF THE COLLAR PLUS 5-1/2".

COLLAR = 3" LONG.

FABRICATION DATA

OUTER BOX: 28 GAUGE GALVANIZED STEEL.

COLLAR: ROLL FORMED 30 GAUGE GALVANIZED STEEL.

FEATURES

INTERNAL INSULATION: R-6.

BLACK INTERIOR.

1/2" DRYWALL FLANGE.

HOLE CLUSTER FOR REGISTER ATTACHMENT.

SOLID CORNERS WITH HANGER HOLES.

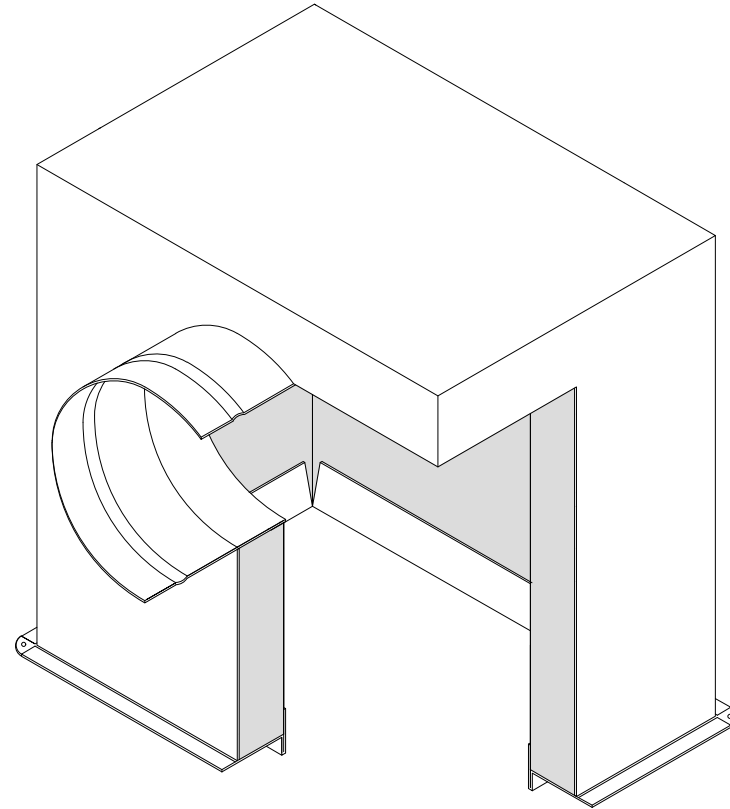

OPTIONS

No. 1269 INSULATED REGISTER BOX WITH R-4.2 INTERNAL INSULATION.

SPECIAL NOTES

INTERNAL INSULATION USED MEETS THE REQUIREMENTS OF ASTM C 1338 (FORMERLY ASTM C 665) STANDARD TEST METHOD FOR FUNGI RESISTANCE.