



6390 Philips Highway
Jacksonville, FL 32216
Phone (904) 737-7144

SPECIFICATION DATA SHEET

Date: 05/08/19 rev. Drawn by: M.D.C.

MODEL No. 616-DSO

TAB COLLAR WITH MANUAL VOLUME DAMPER
& 2" DAMPER HANDLE STANDOFF

DIMENSIONAL DATA

SIZES AVAILABLE: 4" THROUGH 18" DIAMETER

COLLARS ARE 3" LONG FROM FLANGE TO EDGE OF COLLAR.

FABRICATION DATA

FABRICATED FROM HOT DIPPED GALVANIZED STEEL SHEET OF LOCK FORMING QUALITY PER ASTM-653 CS TYPE B.

SIZES 4" THROUGH 12" = 30 GAUGE
SIZES 14" THROUGH 18" = 28 GAUGE

FEATURES

EASY BEND TABS (1/3 LESS TABS TO BEND)

3/4" OUTBOARD FLANGE INTERNALLY SEALED WITH HOT MELT MASTIC.

TABS ARE DESIGNED FOR 1" AND 1-1/2" THICK DUCT BOARD.

MANUAL VOLUME DAMPER WITH 1/4" CONTINUOUS ROD DAMPER AXIS WITH LOCKING REGULATOR, GROMMETS INSTALLED AT THE COLLAR PENETRATIONS.

2" DAMPER HANDLE STANDOFF.

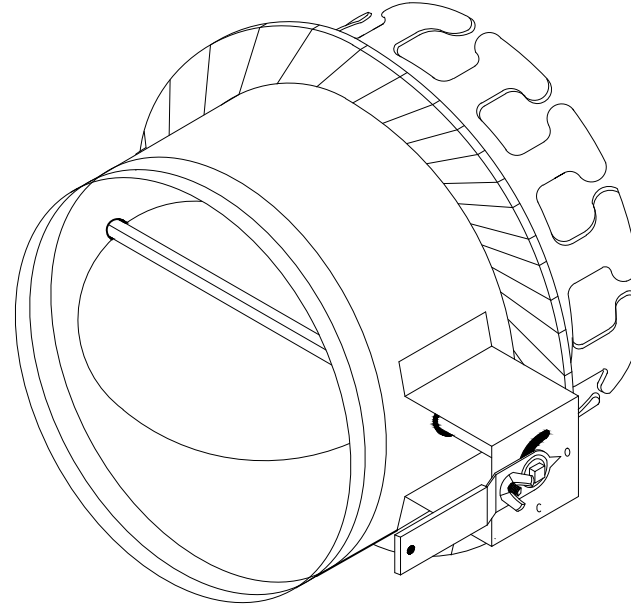

OPTIONS

SPECIAL NOTES

HOT MELT GASKET USED TO SEAL FLANGE BEARS FIRE HAZARD CLASS 1, FLAME SPREAD LESS THAN 25, SMOKE DENSITY LESS THAN 50.