



6390 Philips Highway
 Jacksonville, FL 32216
 Phone (904) 737-7144

SPECIFICATION DATA SHEET

MODEL No. 265

REDUCER / INCREASER

Date: 07/11/22 rev.

Drawn by: J.E.P.

DIMENSIONAL DATA

SIZES: 3" THROUGH 24" DIAMETER

SIZE	LENGTH	SIZE	LENGTH
4" - 3"	8-1/8"	12" - 10"	6-3/4"
5" - 4"	7-1/2"	14" - 8"	9-3/4"
6" - 4", 5"	8-5/8"	14" - 10"	7-3/4"
7" - 4"	10-3/4"	14" - 12"	6-3/4"
7" - 5", 6"	8-1/2"	16" - 12"	8-1/2"
8" - 5"	7-1/4"	16" - 14"	8-1/4"
8" - 6"	7-1/4"	18" - 14"	8-3/4"
8" - 7"	6-1/2"	18" - 16"	8-1/4"
9" - 6"	7"	20" - 16"	8-1/2"
9" - 7"	8-1/4"	20" - 18"	8-5/8"
9" - 8"	6-1/2"	22" - 18"	8-1/2"
10" - 6"	7-3/4"	22" - 20"	8-3/8"
10" - 7"	7"	24" - 20"	8-1/2"
10" - 8"	7"	24" - 22"	8-1/8"
10" - 9"	7-1/4"		
12" - 8"	9-1/2"		
12" - 9"	10"		

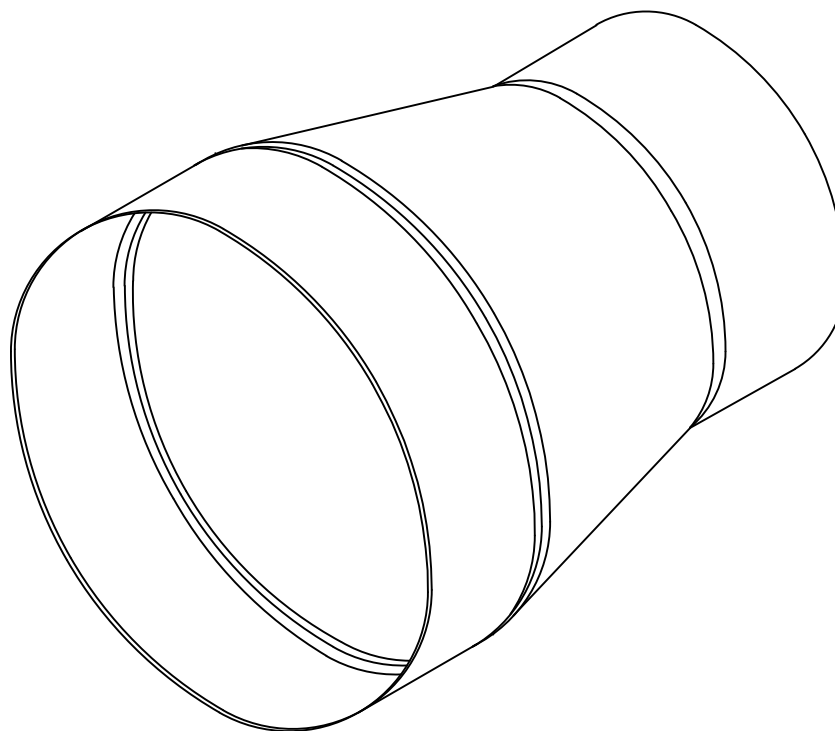

FABRICATION DATA

MATERIAL: FABRICATED FROM GALVANIZED
 STEEL SHEET, ASTM-A653 CS TYPE B.

GAUGES:
 4" THROUGH 12" = 30 GAUGE
 14" THROUGH 18" = 28 GAUGE
 20" THROUGH 24" = 26 GAUGE

FEATURES

TRANSVERSE CONNECTIONS:
 STRAIGHT FEMALE CONNECTION BOTH ENDS

OPTIONS

ALUMINUM AND STAINLESS REDUCERS
 ARE AVAILABLE IN LIMITED GAUGES AND
 DIAMETERS.

SPECIAL NOTES

4" x 3" REDUCER AVAILABLE IN MAXIMUM 26 GAUGE.
 5" THROUGH 9" REDUCERS AVAILABLE IN MAXIMUM 24 GAUGE.
 10" THROUGH 24" REDUCERS AVAILABLE IN MAXIMUM 22 GAUGE.