



6390 Philips Highway  
 Jacksonville, FL 32216  
 Phone (904) 737-7144

**SPECIFICATION DATA SHEET**

**MODEL No. 111**

**ADJUSTABLE 90 DEGREE ELBOW**

Date: 07/11/22 rev.

Drawn by: J.E.P.

**DIMENSIONAL DATA**

SIZES AVAILABLE: 3" THROUGH 24" DIAMETER

DIAMETER	THROAT	DIAMETER	THROAT
3"	2-1/2"	14"	3"
4"	3"	16"	3"
5"	3"	18"	4"
6"	3"	20"	4"
7"	3"	22"	6"
8"	4"	24"	6"
9"	3-1/2"		
10"	3"		
12"	4"		

**FABRICATION DATA**

MATERIAL: GALVANIZED STEEL SHEET OF LOCK FORMING QUALITY PER ASTM-A653 CS TYPE B.

DIAMETER	GAUGES AVAILABLE
3"	30 and 28
4"	30, 28, 26
5" - 9"	30, 28, 26, 24
10"	30, 28, 26, 24, 22
12" - 14"	28, 26, 24, 22
16" - 20"	26, 24, 22
22" - 24"	22

**FEATURES**

TRANSVERSE CONNECTIONS:  
 CRIMPED MALE CONNECTION  
 STRAIGHT FEMALE CONNECTION

CONSTRUCTION:  
 3" THROUGH 20" DIAMETER = 4 PIECE ASSEMBLY  
 22" THROUGH 24" DIAMETER = 5 PIECE ASSEMBLY

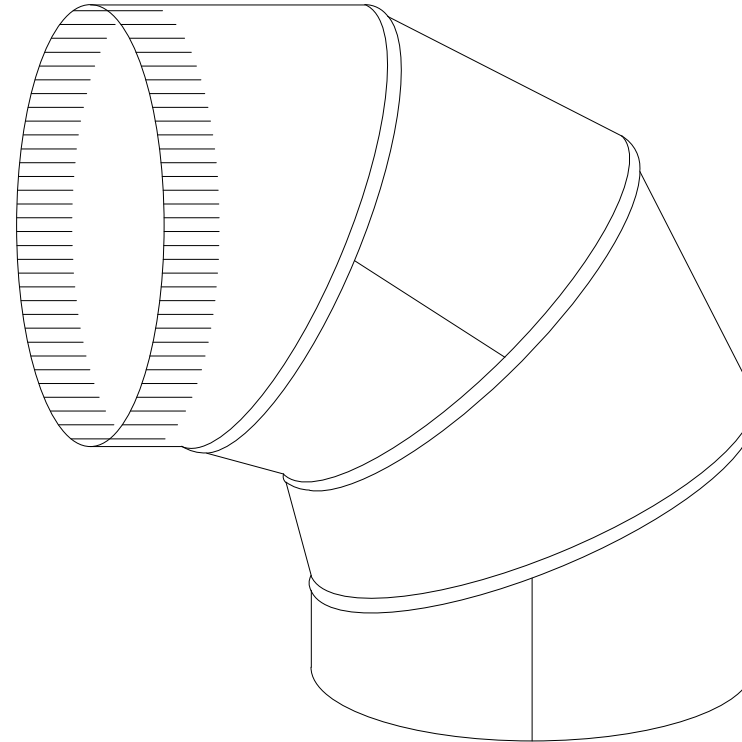

**OPTIONS**

ALUMINUM AND STAINLESS STEEL ELBOWS ARE AVAILABLE IN VARIOUS GAUGES AND DIAMETERS.  
 AVAILABLE IN G-60 AND G-90 COATING WEIGHTS.

**SPECIAL NOTES**

UP TO 10" POSITIVE STATIC PRESSURE PER SMACNA THIRD EDITION 2005:  
 04" - 14" 28 GA  
 16" - 18" 26 GA  
 20" - 24" 24 GA