



6390 Philips Highway
Jacksonville, FL 32216
Phone (904) 737-7144

SPECIFICATION DATA SHEET

Date: 10/12/21

Drawn by: J.E.P.

Model No. 757 SPECIAL DRAIN PAN

DIMENSIONAL DATA

2" DEEP DRAIN PAN

STANDARD SIZES: "A" x "B"

24" x 48"

30" x 60"

30" x 66"

FABRICATION DATA

PAN MATERIAL:

24 GAUGE GALVANIZED STEEL SHEET PER
ASTM-A653 CS TYPE B.

SUPPORTS MATERIAL:

20 GAUGE GALVANIZED STEEL SHEET PER
ASTM-A653 CS TYPE B.

FEATURES

$\frac{3}{4}$ " PVC FEMALE NIPPLE FITTING LOCATED 3"
FROM END ON LONG SIDE (SEE DRAWING)
UNLESS SPECIFIED OTHERWISE

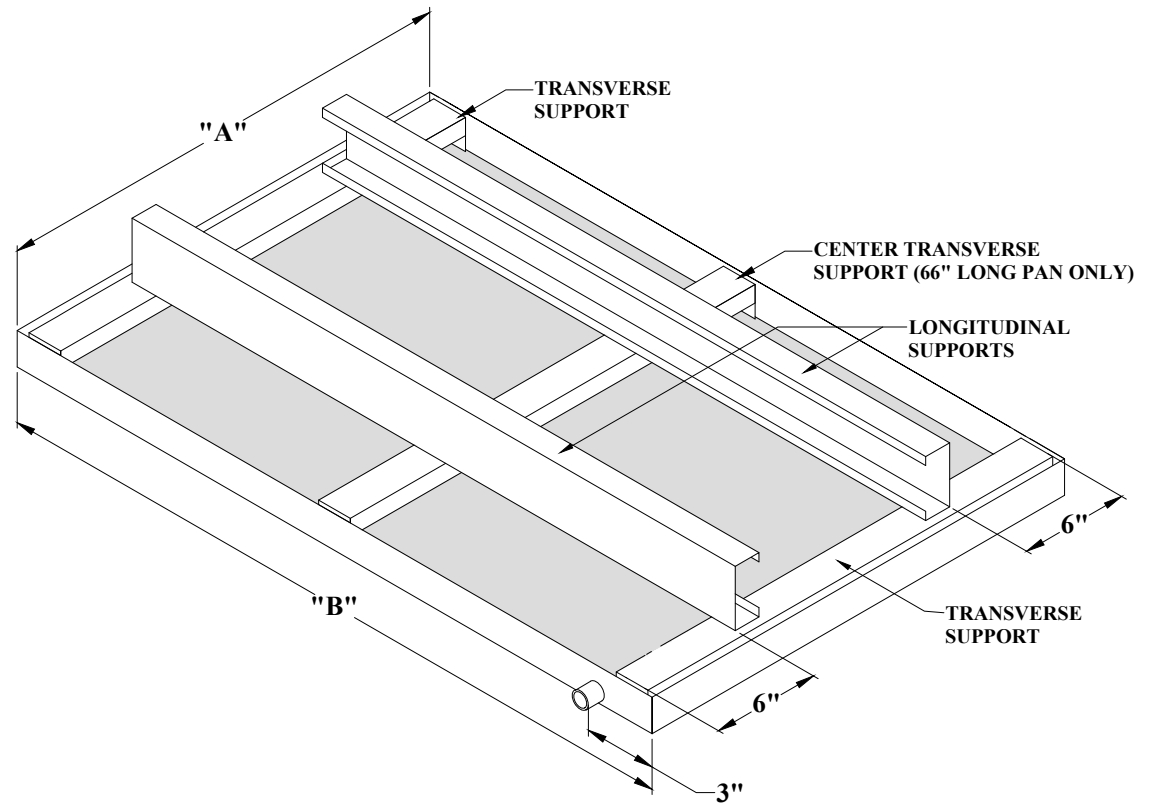

n.t.s.

OPTIONS

SPECIAL NOTES