



6390 Philips Highway  
Jacksonville, FL 32216  
Phone (904) 737-7144

## SPECIFICATION DATA SHEET

# MODEL No. 750

### AUXILIARY DRAIN PAN

Date: 4/11/03 rev.

Drawn by: DON.JR.

#### DIMENSIONAL DATA

CUSTOM BUILT TO MEET SPECIFIC UNIT DIMENSIONS.

STANDARD DEPTH: 1-7/8"

#### FABRICATION DATA

FABRICATED FROM HOT DIPPED GALVANIZED STEEL SHEET OF LOCK FORMING QUALITY PER ASTM-A653 CS TYPE B.

1/2" HEM ON ALL EDGES.

CORNERS SEALED WITH SILICONE SEALANT.

STANDARD GAUGE: 26

#### FEATURES

3/4" FEMALE DRAIN ADAPTER IN CENTER OF SHORT SIDE UNLESS POSITION REQUESTED OTHERWISE.

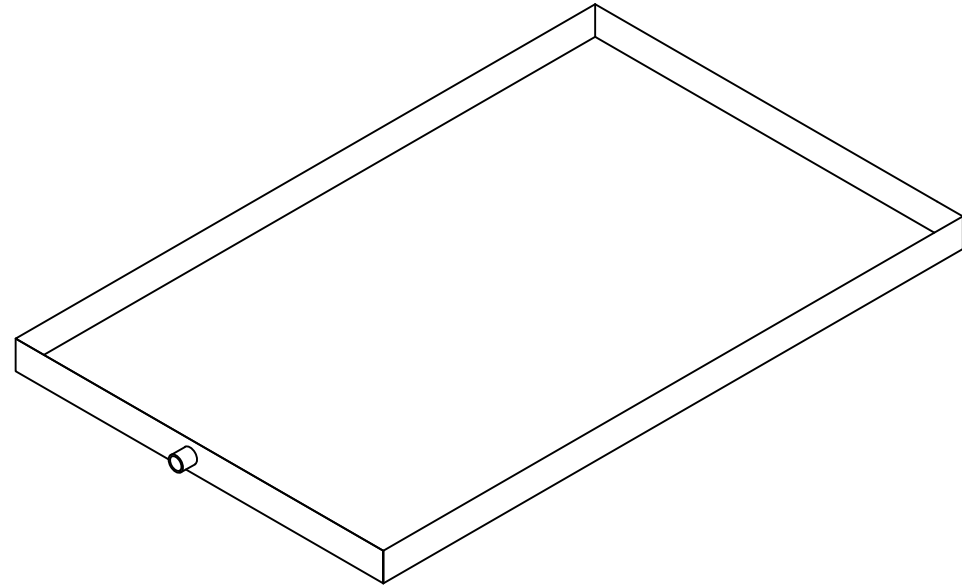

#### OPTIONS

#### SPECIAL NOTES