



6390 Philips Highway
Jacksonville, FL 32216
Phone (904) 737-7144

SPECIFICATION DATA SHEET

Date: 05/02/02 rev. Drawn by: Don. Jr.

MODEL No. 712

STARTING COLLAR WITH GASKET FLANGE
AND SCOOP

DIMENSIONAL DATA

SIZES AVAILABLE: 4" THROUGH 16" DIAMETER
COLLAR LENGTH IS 5-1/2" (ALL DIAMETERS)

FABRICATION DATA

MATERIAL:
HOT DIPPED GALVANIZED STEEL SHEET
PER ASTM-A653 CS TYPE B.

GAUGES:
4" THROUGH 10" = 30 GAUGE
12" THROUGH 16" = 28 GAUGE

FEATURES

1" WIDE FLANGE WITH GASKET MATERIAL AND
PRE-DRILLED SCREW HOLES FOR EASE OF
INSTALLATION.

SCOOP PENETRATES INTO TRUNK DUCT AIR
STREAM.

CRIMP AND BEAD TRANSVERSE CONNECTION.
OVERLAP AND RIVETED LONGITUDINAL SEAM.

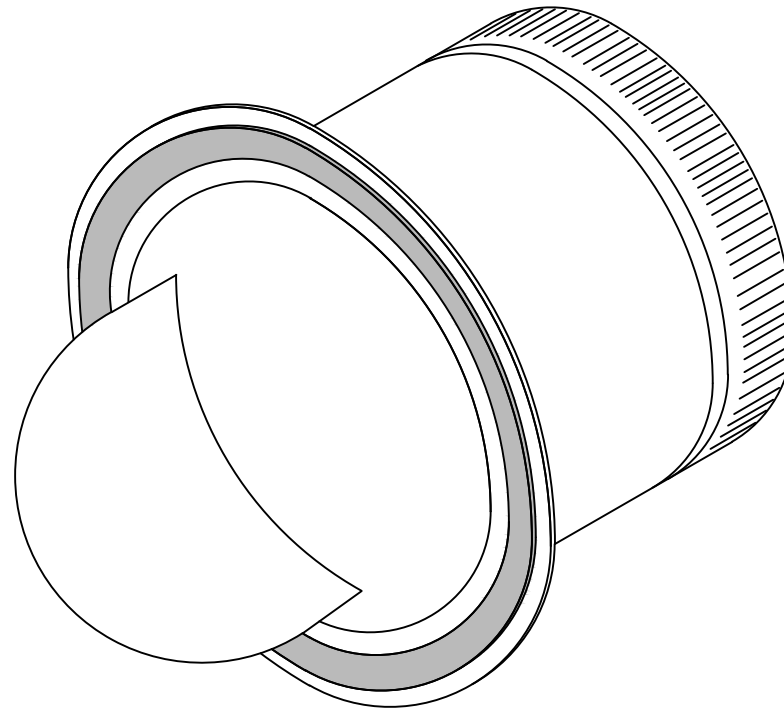

OPTIONS

No. 710: TAKE OFF WITH THERMA GASKET SEAL
No. 714: TAKEOFF WITH THERMA GASKET SEAL
AND MANUAL VOLUME DAMPER.
No. 716: TAKEOFF WITH THERMA GASKET SEAL,
SCOOP AND MANUAL VOLUME DAMPER.

SPECIAL NOTES