



6390 Philips Highway  
Jacksonville, FL 32216  
Phone (904) 737-7144

## SPECIFICATION DATA SHEET

## MODEL No. 710

STARTING COLLAR WITH GASKET FLANGE

Date: 05/02/02 rev.

Drawn by: Don. Jr.

### DIMENSIONAL DATA

SIZES AVAILABLE: 4" THROUGH 16" DIAMETER  
COLLAR LENGTH IS 5-1/2" (ALL DIAMETERS)

### FABRICATION DATA

MATERIAL:  
HOT DIPPED GALVANIZED STEEL SHEET  
PER ASTM-A653 CS TYPE B.  
GAUGES:  
4" THROUGH 10" = 30 GAUGE  
12" THROUGH 16" = 28 GAUGE

### FEATURES

1" WIDE FLANGE WITH GASKET MATERIAL AND  
PRE-DRILLED SCREW HOLES FOR EASE OF  
INSTALLATION.  
CRIMP AND BEAD TRANSVERSE CONNECTION.  
OVERLAP AND RIVETED LONGITUDINAL SEAM.

### AIR FLOW CHARACTERISTICS

BASED ON 700 F/M VELOCITY IN MAIN DUCT;  
600 F/M VELOCITY IN BRANCH DUCT.  
DESIGN FRICTION LOSS OF .15" W.G. PER 100 FT.  
OF DUCT. PRESSURE LOSS IN EQUIVALENT FEET  
OF BRANCH DUCT = 25 FT.

### OPTIONS

- No. 712: TAKE OFF WITH THERMA GASKET SEAL  
AND SCOOP.
- No. 714: TAKEOFF WITH THERMA GASKET SEAL  
AND MANUAL VOLUME DAMPER.
- No. 716: TAKEOFF WITH THERMA GASKET SEAL,  
SCOOP AND MANUAL VOLUME DAMPER.

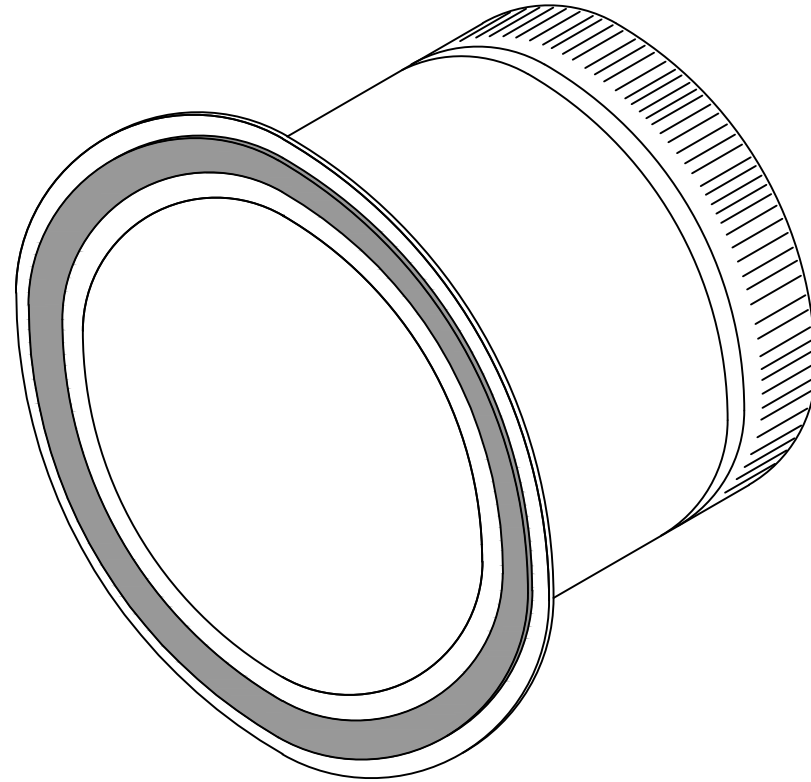

### SPECIAL NOTES