



6390 Philips Highway
Jacksonville, FL 32216
Phone (904) 737-7144

SPECIFICATION DATA SHEET

Date: 3/31/03 rev.

Drawn by: Don. JR.

MODEL No. 656

RING SEAL COLLAR with SCOOP and
MANUAL VOLUME DAMPER

DIMENSIONAL DATA

SIZES AVAILABLE: 4" THROUGH 16" DIAMETER

COLLAR LENGTH: 4-1/4"

FABRICATION DATA

MATERIAL:
FABRICATED FROM HOT DIPPED GALVANIZED
STEEL SHEETS PER ASTM-A653 CS TYPE B.

COLLAR: 30 GAUGE GALVANIZED STEEL

DAMPER: 4" THROUGH 10" 28GA.
12" THROUGH 16" 26GA.

SCOOP: 30 GAUGE GALVANIZED STEEL

"CAP": 26 GAUGE GALVANIZED STEEL

RIVETED LONGITUDINAL SEAM

FEATURES

CRIMP AND BEAD MALE TRANSVERSE
CONNECTION.

POCKET OF RING SEAL COLLAR MAINTAINS
FULL 1-1/2" INSULATION THICKNESS.

MANUAL VOLUME DAMPER INSTALLED.
SIZES 4" THROUGH 10" HAVE DAMPER WITH 1/4"
REGULATOR.

SIZES 12" THROUGH 16" HAVE REINFORCED
DAMPER AXIS WITH 1/4" REGULATOR, END
BEARING WITH WASHER AND WING NUT.

SCREW HOLES.

SCOOP INSTALLED.

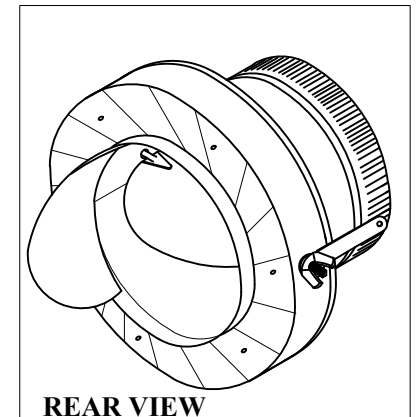
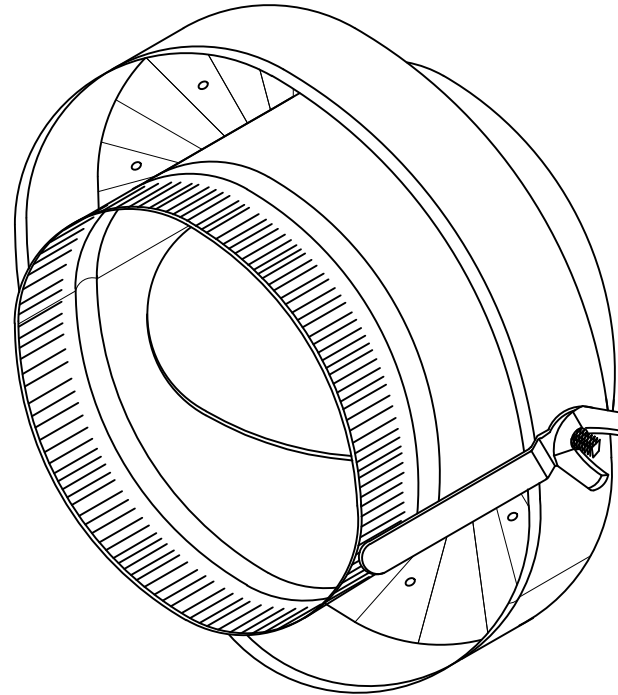

OPTIONS

No. 650 RING SEAL COLLAR
No. 652 RING SEAL COLLAR WITH SCOOP
No. 654 RING SEAL COLLAR WITH MANUAL
VOLUME DAMPER

SPECIAL NOTES