



6390 Philips Highway
Jacksonville, FL 32216
Phone (904) 737-7144

SPECIFICATION DATA SHEET

MODEL No. 650

RING SEAL COLLAR

Date: 3/31/03 rev.

Drawn by: Don. JR.

DIMENSIONAL DATA

SIZES AVAILABLE: 4" THROUGH 16" DIAMETER

COLLAR LENGTH: 4-1/4"

FABRICATION DATA

MATERIAL:
FABRICATED FROM HOT DIPPED GALVANIZED
STEEL SHEETS PER ASTM-A653 CS TYPE B.

COLLAR: 30 GAUGE GALVANIZED STEEL

"CAP": 26 GAUGE GALVANIZED STEEL

RIVETED LONGITUDINAL SEAM

FEATURES

CRIMP AND BEAD MALE TRANSVERSE
CONNECTION.

POCKET OF RING SEAL COLLAR MAINTAINS
FULL 1-1/2" INSULATION THICKNESS.

SCREW HOLES.

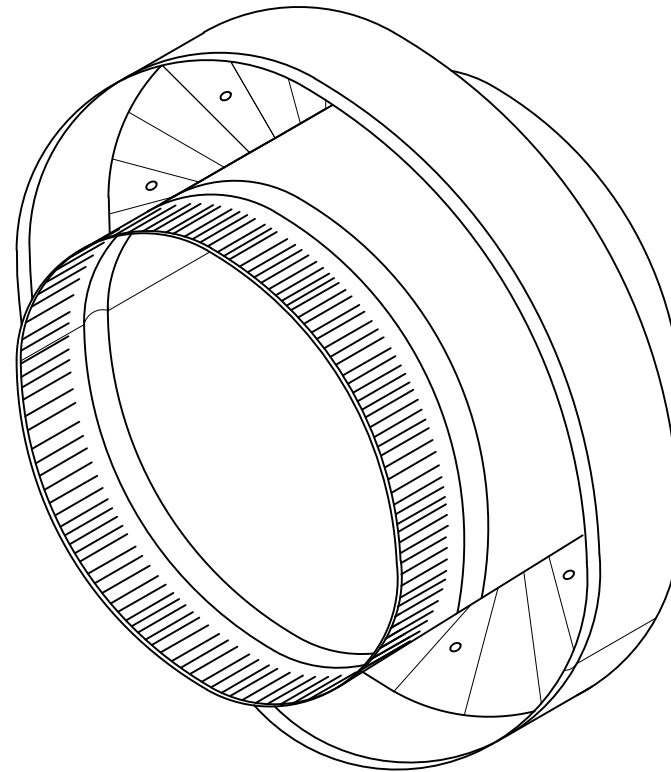

OPTIONS

No. 652 RING SEAL COLLAR WITH SCOOP
No. 654 RING SEAL COLLAR WITH MANUAL
VOLUME DAMPER
No. 656 RING SEAL COLLAR WITH SCOOP
AND MANUAL VOLUME DAMPER

SPECIAL NOTES