



6390 Philips Highway
Jacksonville, FL 32216
Phone (904) 737-7144

SPECIFICATION DATA SHEET

Date: 05/21/02

Drawn by: M.D.C.

MODEL No. 616-G

TAB COLLAR with THERMA SEAL GASKET

DIMENSIONAL DATA

SIZES AVAILABLE: 4" THROUGH 20" DIAMETER

COLLARS ARE 3" LONG FROM FLANGE TO EDGE OF COLLAR.

FABRICATION DATA

FABRICATED FROM HOT DIPPED GALVANIZED STEEL SHEET OF LOCK FORMING QUALITY PER ASTM-A653 CS TYPE B.

SIZES 4" THROUGH 12" = 30 GAUGE
SIZES 14" THROUGH 20" = 28 GAUGE

FEATURES

NEW - EASY BEND TABS (1/3 LESS TABS TO BEND)

THERMA SEAL GASKET ATTACHED TO THE OUTBOARD FLANGE.

3/4" OUTBOARD FLANGE INTERNALLY SEALED WITH HOT MELT MASTIC.

TABS ARE DESIGNED FOR 1" AND 1-1/2" THICK DUCT BOARD.

PRE-DRILLED DAMPER HOLES.

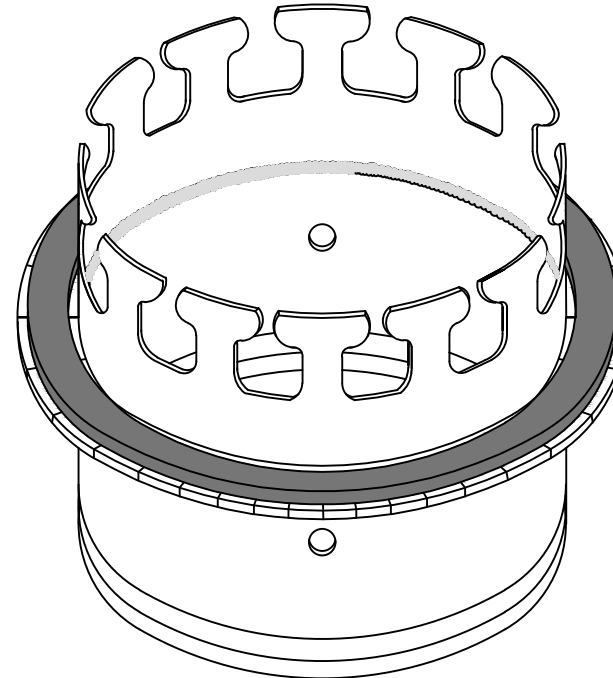

OPTIONS

SPECIAL NOTES

HOT MELT MASTIC USED TO SEAL FLANGE BEARS FIRE HAZARD CLASS 1, FLAME SPREAD LESS THAN 25, SMOKE DENSITY LESS THAN 50.

THERMA SEAL GASKET ATTACHED TO OUTBOARD FLANGE BEARS FIRE HAZARD CLASS 1, FLAME SPREAD LESS THAN 25, SMOKE DENSITY LESS THAN 50.