



6390 Philips Highway  
Jacksonville, FL 32216  
Phone (904) 737-7144

## SPECIFICATION DATA SHEET

Date: 07/18/07 rev.

Drawn by: M.D.C.

## MODEL No. 500

ADJUSTABLE AIR HANDLER STAND

### DIMENSIONAL DATA

WIDTH: 14" - 25" (ADJUSTABLE)  
DEPTH: 22" (FIXED)  
HEIGHT: 18" (FIXED)  
LEGS: 3" x 3"

### FABRICATION DATA

MATERIAL: 18 GAUGE GALVANIZED STEEL,  
ASTM-A653 CS TYPE B.  
SPOT WELDED SEAM CONSTRUCTION.

### FEATURES

STAND FITS MOST SIZES OF 1-1/2 THROUGH 3 TON  
AIR HANDLERS.

SET STAND TO DESIRED WIDTH TO FIT AIR  
HANDLER. FASTEN TELESCOPING ANGLES WITH  
SHEET METAL SCREWS.

BUILT-IN FILTER RACK FOR 1" THICK FILTER.

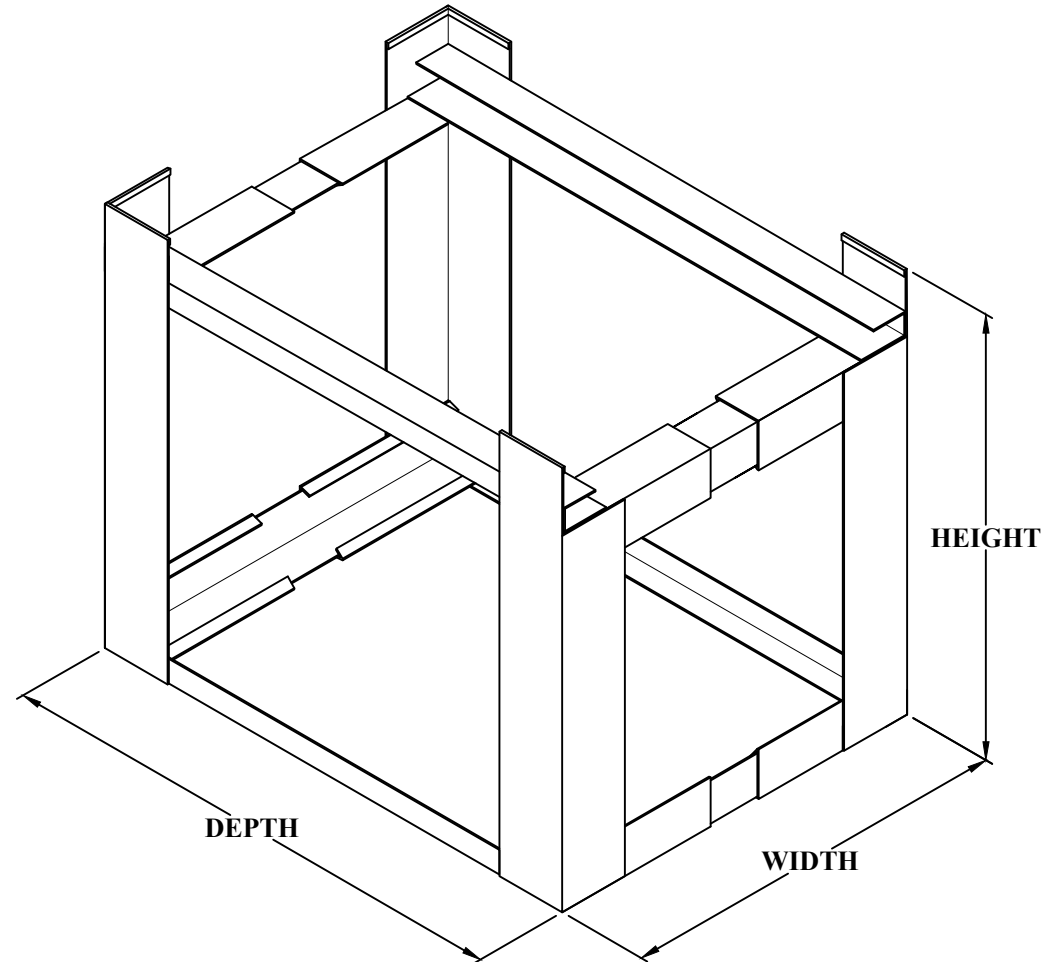

### OPTIONS

No. 500-28 AIR HANDLER STAND (DEPTH IS 28")

No. 600 ADJUSTABLE AIR HANDLER STAND

### SPECIAL NOTES