



6390 Philips Highway
Jacksonville, FL 32216
Phone (904) 737-7144

SPECIFICATION DATA SHEET

MODEL No. 480

RECTANGLE TO ROUND TRANSITION

Date: 09/12/07 rev. Drawn by: M.D.C.

DIMENSIONAL DATA

RECTANGULAR END: SIZED AS REQUIRED FOR UNIT OPENING OR DUCT SIZE.

ROUND END: SIZED AS REQUIRED, MAXIMUM 24" DIAMETER.

OVERALL HEIGHT: 12" (STANDARD)

2" LONG COLLAR STANDARD.

FABRICATION DATA

MATERIAL: FABRICATED FROM HOT DIPPED GALVANIZED STEEL SHEET OF LOCK FORMING QUALITY PER ASTM-A653 CS TYPE B.

STANDARD GAUGES (BASED ON COLLAR SIZE):
UP THROUGH 12" DIAMETER: 28 GAUGE
14" THROUGH 24" DIAMETER: 26 GAUGE
ALL DIAMETERS AVAILABLE IN 26 & 24 GA.
10" DIA. & LARGER AVAILABLE IN 22 GA.

RIVETED LONGITUDINAL SEAM.

FEATURES

CENTER LINE TAPER STANDARD.

S-LOCKS STANDARD ON RECTANGULAR END.
TURN FOR DRIVE CLEATS AVAILABLE.
INBOARD OR OUTBOARD FLANGE AVAILABLE.

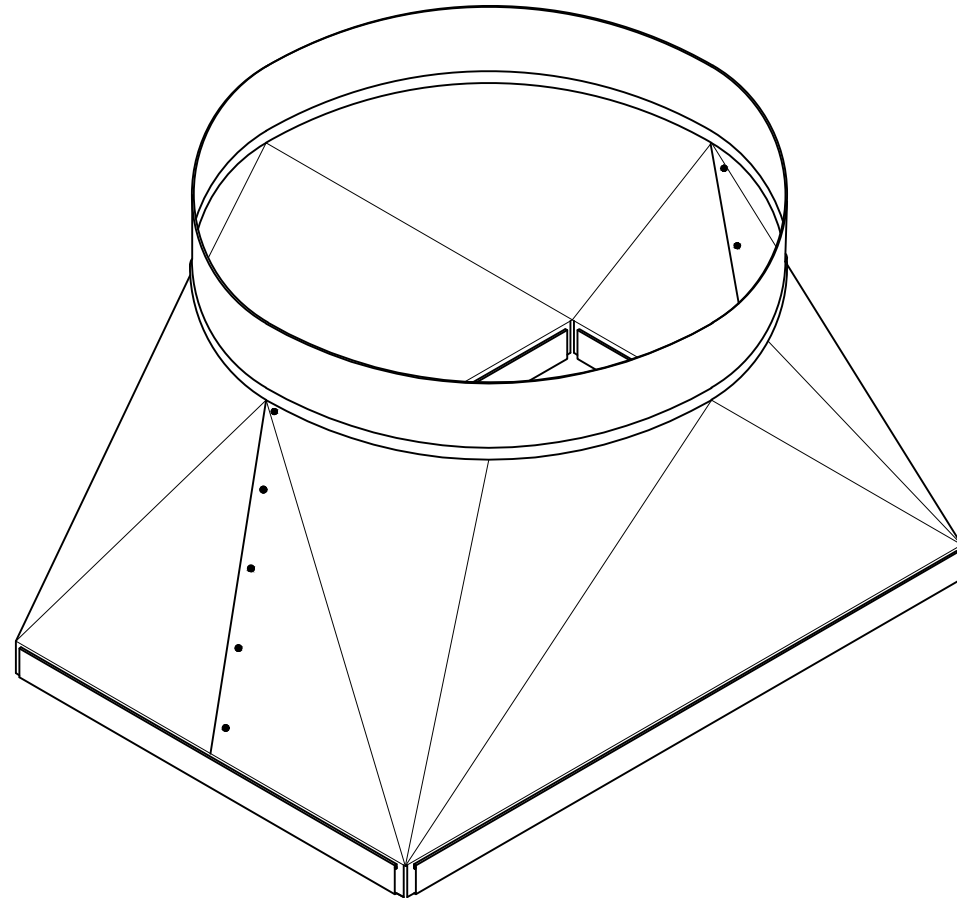

OPTIONS

OFFSET TRANSITION.

3" LONG COLLAR FOR FLEX CONNECTION.

INTERNALLY INSULATED:

No. 1480 with R-4.2 LINER

No. 1480-FL with R-6 LINER

SPECIAL NOTES

AVAILABLE UPON REQUEST:

1) FABRICATED FROM .018" THICK (26 GA.) STAINLESS STEEL TYPE 304-2B

2) FABRICATED FROM .025" THICK OR .032" THICK ALUMINUM SHEET 3003 H-14 ALLOY