



6390 Philips Highway  
Jacksonville, FL 32216  
Phone (904) 737-7144

## SPECIFICATION DATA SHEET

**MODEL No. 450**  
UNIVERSAL ACCESS DOOR

Date: 1/27/23 rev.

Drawn by: J.E.P

### DIMENSIONAL DATA

#### STANDARD SIZES:

6" X 6"	14" X 14"	22" X 22"
8" X 8"	16" X 16"	24" X 24"
10" X 10"	18" X 18"	
12" X 12"	20" X 20"	

### FABRICATION DATA

**MATERIAL:**  
FABRICATED FROM HOT DIPPED GALVANIZED  
STEEL SHEETS OF LOCK FORMING QUALITY  
PER ASTM-A653 CS TYPE B.

**DOOR CONSTRUCTION:**  
DOOR BODY AND FRAME = 24 GA. GALVANIZED  
DOVETAILS = 26 GA. GALVANIZED

DOOR SIZES 6" X 6"- 16" X 16" ARE PROVIDED  
WITH 2 CAM LOCKS. LARGER DOORS HAVE  
4 CAM LOCKS.

### FEATURES

OUTER FLANGE IS FABRICATED WITH A  
GASKET AND SCREW HOLES FOR EASY  
INSTALLATION.

INNER FRAME AROUND DOOR IS FABRICATED  
WITH A GASKET TO PROVIDE AN AIR TIGHT  
SEAL.

DESIGNED FOR INSTALLATION IN SHEET  
METAL OR 1" AND 1-1/2" DUCTBOARD.  
1" THICK INSULATION IN DOOR PANEL

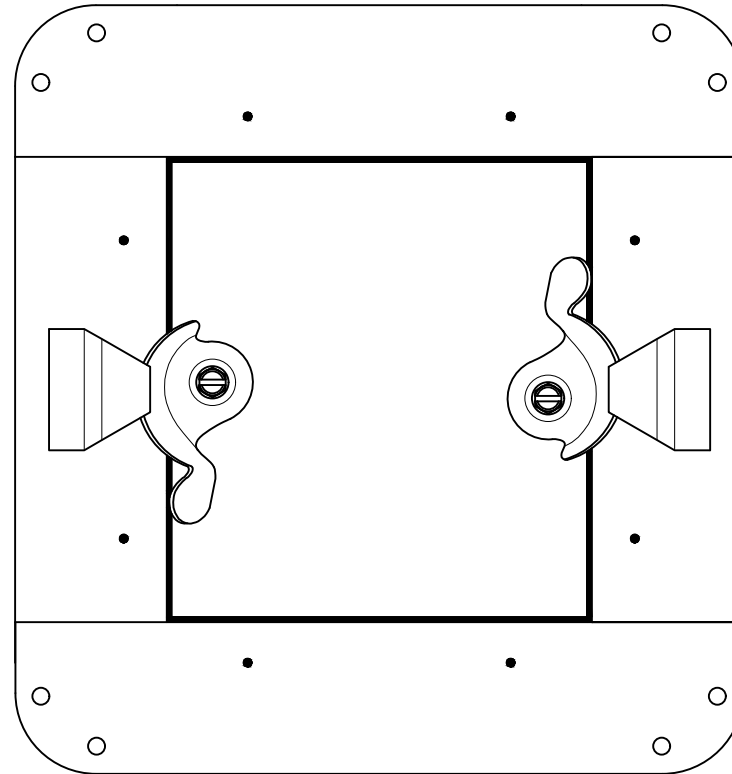

### OPTIONS

NON-STANDARD SIZES AVAILABLE UPON  
REQUEST.

### SPECIAL NOTES