



6390 Philips Highway
Jacksonville, FL 32216
Phone (904) 737-7144

SPECIFICATION DATA SHEET

Date: 05/12/08

Drawn by: M.D.C.

Model No. 422-S RECTANGULAR MANUAL VOLUME DAMPER

DIMENSIONAL DATA

AS REQUIRED: PER DUCT DIMENSIONS "W" x "H"
(UNDERSIZED $\frac{1}{4}$ " EACH WAY).

DAMPER AXIS ROD EXTENDS 2" PAST EDGE OF
DAMPER.

FABRICATION DATA

MATERIAL:
22 GAUGE HOT DIPPED GALVANIZED STEEL
SHEET PER ASTM-A653 CS TYPE B.

FEATURES

"W" = 18" OR GREATER: CONTINUOUS $\frac{1}{2}$ " x $\frac{1}{2}$ "
SQUARE ROD AS DAMPER AXIS NESTED IN
GROOVE WITH STRAPS SPOT WELDED TO
DAMPER BLADE AND ROD SECURED TO STRAPS
WITH SCREW.

"W" = LESS THAN 18": 2 EACH 4" LONG $\frac{1}{2}$ " x $\frac{1}{2}$ "
SQUARE RODS AS DAMPER AXIS NESTED IN
GROOVE WITH STRAPS SPOT WELDED TO
DAMPER BLADE AND ROD SECURED TO STRAPS
WITH SCREW.

INCLUDES HANDLE REGULATOR.

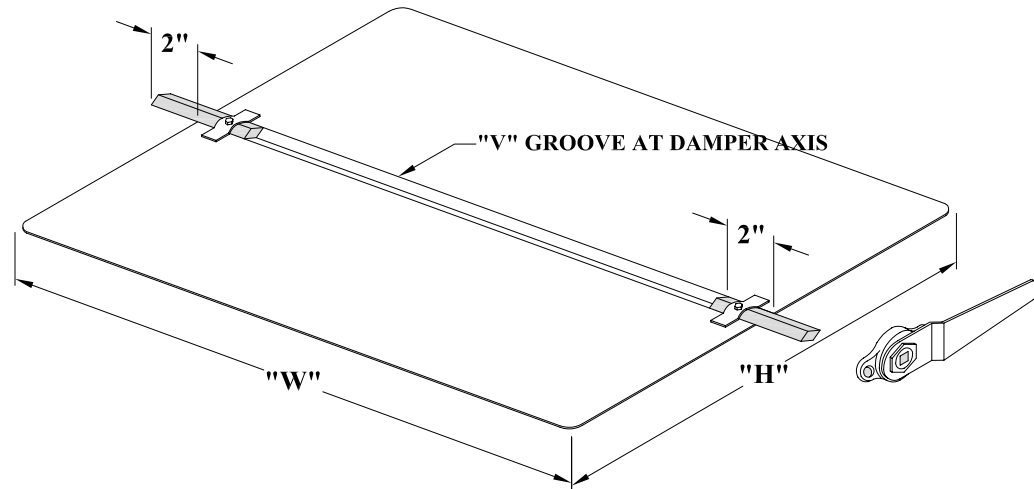
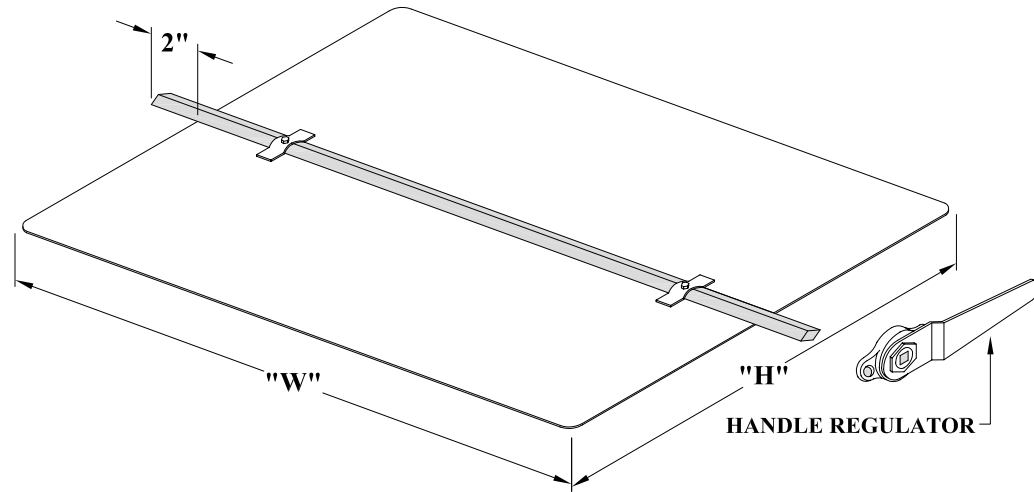

OPTIONS

SPECIAL NOTES