



6390 Philips Highway
Jacksonville, FL 32216
Phone (904) 737-7144

SPECIFICATION DATA SHEET

Date: 05/11/20 rev.

Drawn by: M.D.C.

MODEL No. 3200-DS

CONICAL SPIN-IN
MANUAL VOLUME DAMPER with
DAMPER HANDLE STANDOFF

DIMENSIONAL DATA

SIZES AVAILABLE: 4" THROUGH 20"

CONICAL CONNECTION HOLE TO TRUNK DUCT IS APPROXIMATELY 2" GREATER THAN BRANCH DUCT DIMENSION.

5 3/8" LONG COLLAR.

FABRICATION DATA

MATERIAL:
HOT DIPPED GALVANIZED STEEL SHEET
PER ASTM-A653 CS TYPE B.

SIZE	BODY	DAMPER BLADE
4" - 8"	28 GA.	24 GA.
9" - 14"	26 GA.	24 GA.
16" - 20"	24 GA.	22 GA.

FEATURES

CONTINUOUS WELD LONGITUDINAL SEAM FOR NO AIR LEAKAGE @ 2" W.G. STATIC PRESSURE.

2" DAMPER HANDLE STANDOFF TO ALLOW CLEARANCE FOR EXTERNAL INSULATION.

SIZES 4" THROUGH 12" HAVE MANUAL VOLUME DAMPER WITH 1/4" CONTINUOUS ROD DAMPER AXIS WITH LOCKING REGULATOR, GROMMETS INSTALLED AT THE COLLAR PENETRATIONS.

SIZES 14" THROUGH 20" HAVE A 3/8" CONTINUOUS ROD DAMPER AXIS WITH NYLON GROMMETS INSTALLED AT COLLAR PENETRATIONS.

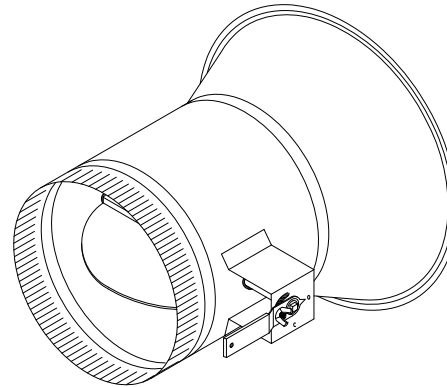

CONFIGURATION OF
4" THROUGH 12" DIAMETERS

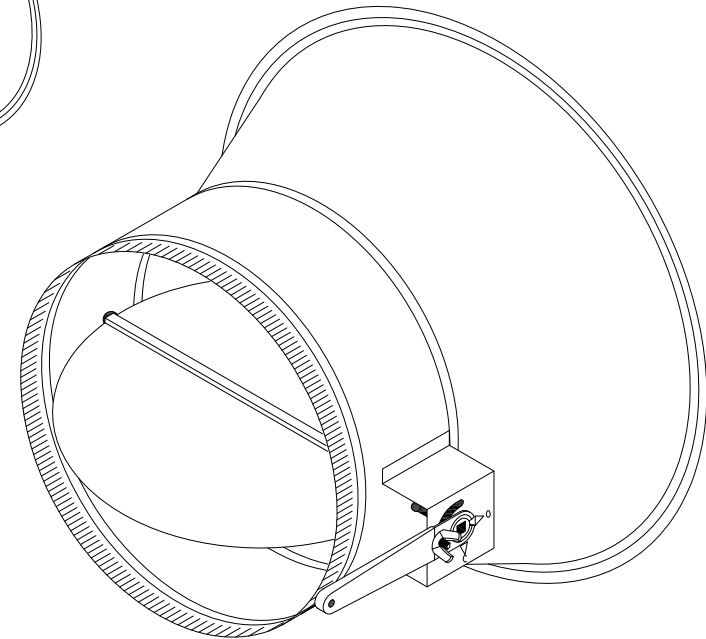

CONFIGURATION OF
14" THROUGH 20" DIAMETERS

OPTIONS

TAKEOFF BODY AND DAMPER BLADE CAN BE FABRICATED FROM .025" THICK 22 GAUGE ALUMINUM 3003-H14 ALLOY.

SPECIAL NOTES

NOTE BRANCH DUCT DIMENSION WHEN ORDERING.

RECOMMENDED INSTALLATION: DAMPER AXIS PARALLEL TO AIR FLOW.

MADE TO MEET S.M.A.C.N.A. GAUGE STANDARDS. MAXIMUM 10" W.G. STATIC PRESSURE SCHEDULE. (S.M.A.C.N.A. HVAC DUCT CONSTRUCTION STANDARDS, THIRD EDITION-2005)