



6390 Philips Highway  
Jacksonville, FL 32216  
Phone (904) 737-7144

## SPECIFICATION DATA SHEET

Date: 06/27/02 rev. Drawn by: M.D.C.

## MODEL No. 232

RANGE HOOD TRANSITION

### DIMENSIONAL DATA

3-1/4" x 10" - 6" & 7" DIAMETER

3" STRAIGHT AWAY ON RECTANGULAR END.

### FABRICATION DATA

FABRICATED FROM 30 GAUGE GALVANIZED  
STEEL OF LOCK FORMING QUALITY PER  
ASTM-A653 CS TYPE B.

### FEATURES

FLAT ON ONE 10" SIDE.

### OPTIONS

OTHER SIZES AND GAUGES AVAILABLE UPON  
REQUEST.

### SPECIAL NOTES

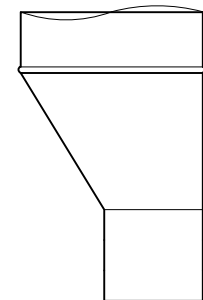
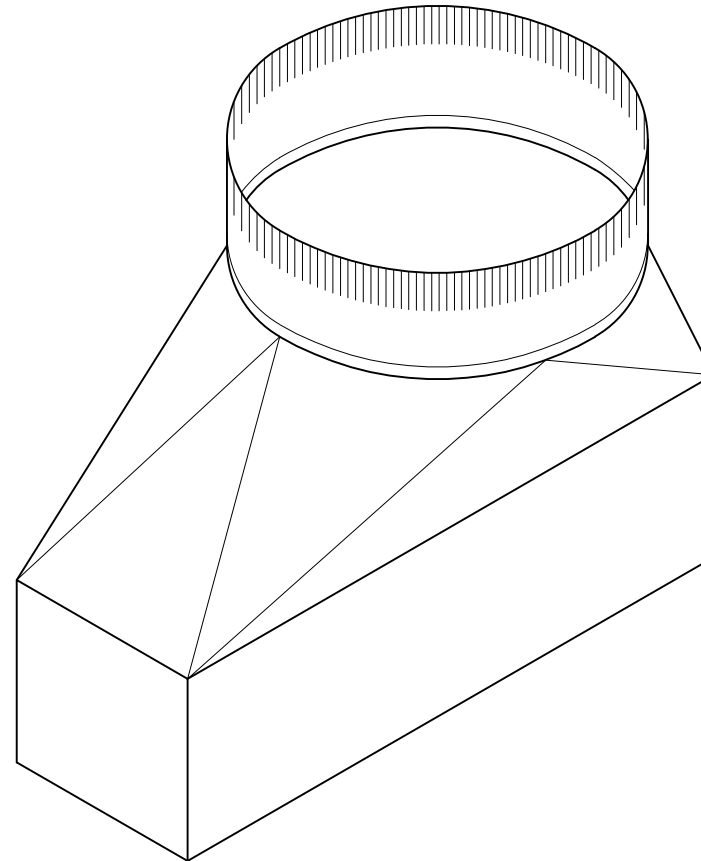

**SIDE VIEW**