



6390 Philips Highway
Jacksonville, FL 32216
Phone (904) 737-7144

SPECIFICATION DATA SHEET

Date: 04/13/04

Drawn by: M.D.C.

MODEL No. 1580-G

INSULATED REGISTER BOX
with THERMA SEAL GASKET

DIMENSIONAL DATA

4-1/2" HIGH FRAMED BOX.

3" LONG COLLAR WITH CONVEX BEAD.

OUTER BOX DIMENSION IS 3" GREATER THAN REGISTER DIMENSION.

FABRICATION DATA

FABRICATED FROM 30 GAUGE GALVANIZED STEEL.

INTERNALLY INSULATED WITH R-6 INSULATION.

FEATURES

BLACK INTERIOR.

SOLID CORNERS WITH HANGER HOLES.

1/2" DRYWALL FLANGE.

5 HOLE CLUSTER FOR REGISTER ATTACHMENT.

GASKET AROUND REGISTER OPENING SEALS BOX WHERE IT PENETRATES BUILDING ENVELOPE.

OPTIONS

No. 1575-G INSULATED REGISTER BOX, R-6 INTERNAL INSULATION, NO FIBER GLASS EXPOSED TO AIRSTREAM.

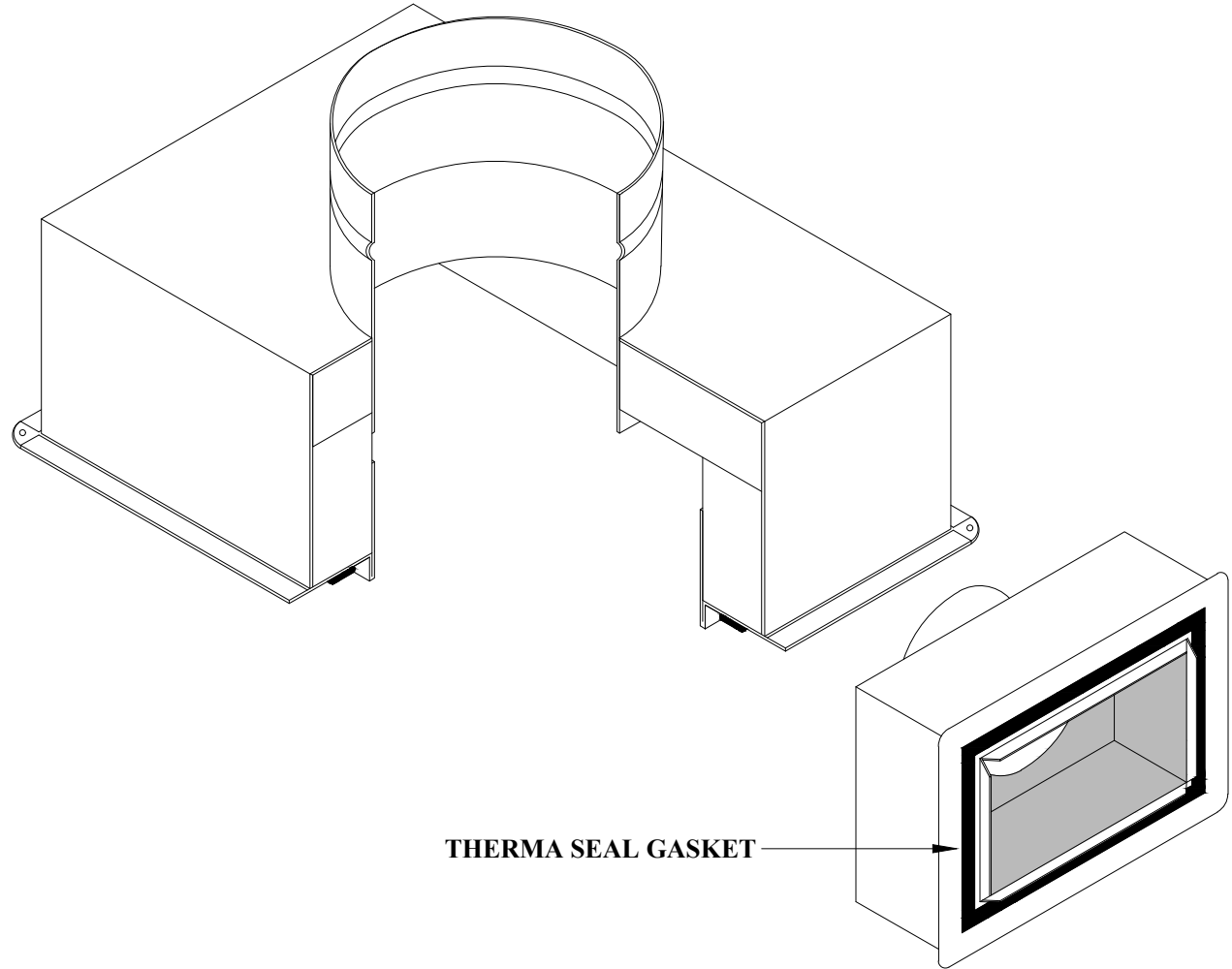

SPECIAL NOTES

GASKET TESTED TO ASTM E-84-91. FLAME SPREAD LESS THAN 25, SMOKE DENSITY LESS THAN 50.
INTERNAL INSULATION USED MEETS THE REQUIREMENTS OF ASTM C 1338 (FORMERLY ASTM C 665)
STANDARD TEST FOR FUNGI RESISTANCE.