



6390 Philips Highway
Jacksonville, FL 32216
Phone (904) 737-7144

SPECIFICATION DATA SHEET

Date: 08/24/04 rev.

Drawn by: M.D.C.

MODEL No. 1275

INSULATED REGISTER BOX

DIMENSIONAL DATA

4-1/2" HIGH FRAMED BOX

3" LONG COLLAR WITH CONVEX BEAD

OUTER BOX DIMENSION IS 3" GREATER THAN REGISTER DIMENSION.

FABRICATION DATA

MATERIAL:
30 GAUGE GALVANIZED STEEL SHEET PER
ASTM A653 CS TYPE B.

INTERNALLY INSULATED WITH R-4.2 INSULATION.

FEATURES

BLACK INTERIOR

SOLID CORNERS WITH HANGER HOLES.

1/2" DRYWALL FLANGE.

5 HOLE CLUSTER FOR REGISTER ATTACHMENT.

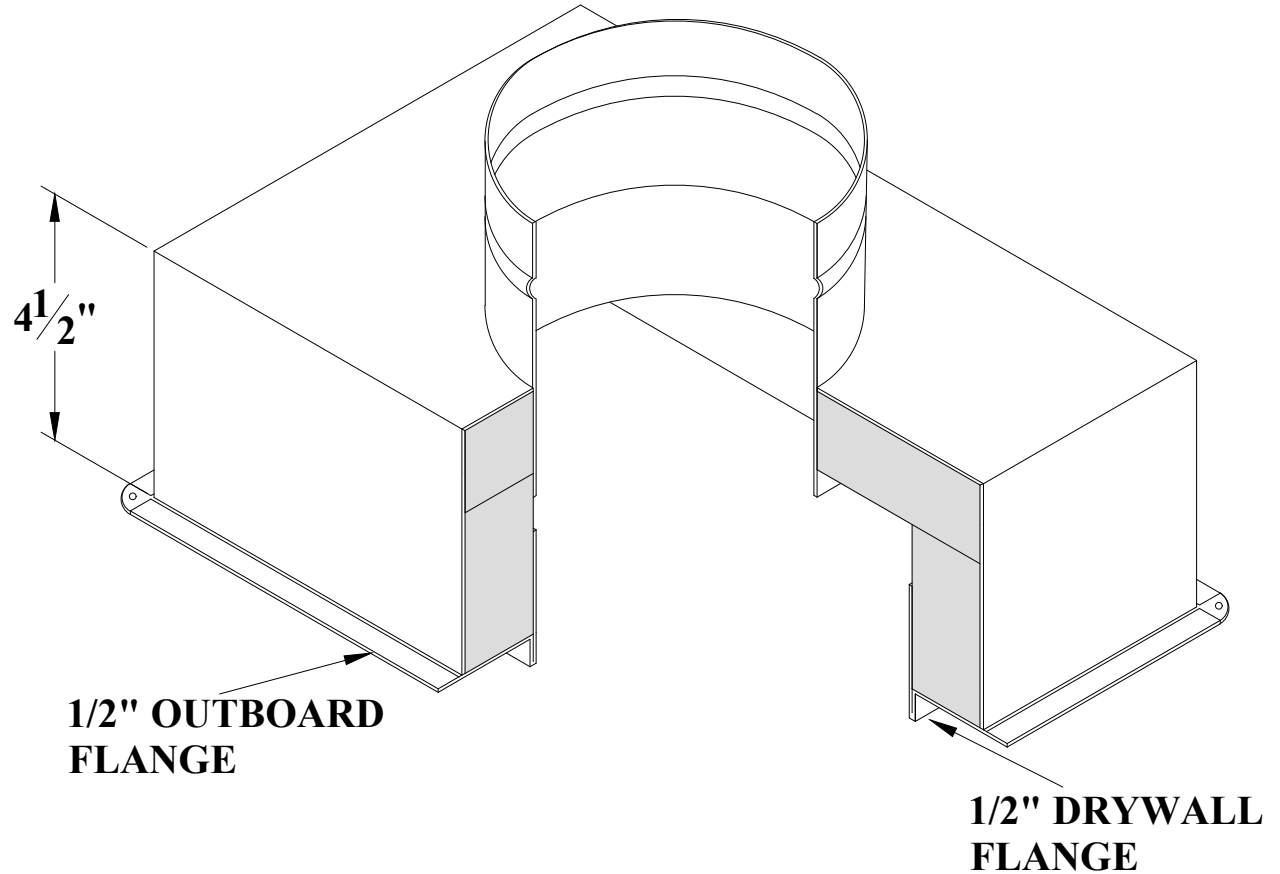

OPTIONS

SPECIAL NOTES

INTERNAL INSULATION USED MEETS THE REQUIREMENTS OF ASTM C 1338 (FORMERLY ASTM C 665) STANDARD TEST FOR FUNGI RESISTANCE.