



6390 Philips Highway
Jacksonville, FL 32216
Phone (904) 737-7144

SPECIFICATION DATA SHEET

Date: 08/24/04

Drawn by: DON. JR.

MODEL No. 1242

FRAMED R-4.2 INSULATED BOOT

DIMENSIONAL DATA

OUTER BOX DIMENSION IS 2" GREATER THAN REGISTER DIMENSION.

FABRICATION DATA

MATERIAL:
30 GAUGE GALVANIZED STEEL SHEET PER
ASTM A653 CS TYPE B.

INTERNALLY INSULATED WITH R-4.2 INSULATION.

FEATURES

3" STRAIGHT AWAY ON RECTANGULAR END.

ROUND COLLAR HAS HEMMED EDGE.

SOLID CORNERS WITH HANGER HOLES.

1/2" DRYWALL FLANGE.

HOLE CLUSTER FOR REGISTER ATTACHMENT.

BLACK INTERIOR.

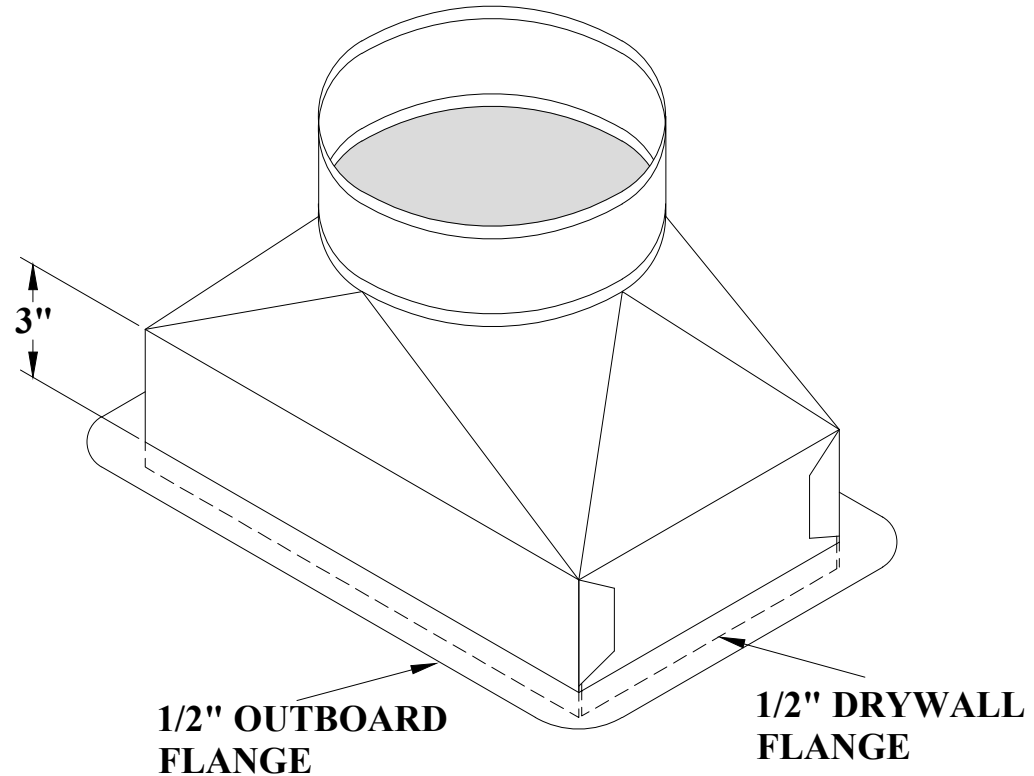

OPTIONS

No. 1242-FL FRAMED INSULATED BOOT, R-6.0
INSULATION, BLACK INTERIOR.

SPECIAL NOTES

INTERNAL INSULATION USED MEETS THE REQUIREMENTS OF ASTM C 1338 (FORMERLY ASTM C 665)
STANDARD TEST METHOD FOR FUNGI RESISTANCE.