



6390 Philips Highway
Jacksonville, FL 32216
Phone (904) 737-7144

SPECIFICATION DATA SHEET

MODEL No. 1242-FL

FRAMED R-6.0 INSULATED BOOT

Date: 03/07/05

Drawn by: DON. JR.

DIMENSIONAL DATA

OUTER BOX DIMENSION IS 3" GREATER THAN REGISTER DIMENSION.

FABRICATION DATA

MATERIAL:
30 GAUGE GALVANIZED STEEL SHEET PER
ASTM A653 CS TYPE B.

INTERNALLY INSULATED WITH R-6.0 INSULATION.

FEATURES

3" STRAIGHT AWAY ON RECTANGULAR END.

ROUND COLLAR HAS HEMMED EDGE.

SOLID CORNERS WITH HANGER HOLES.

1/2" DRYWALL FLANGE.

HOLE CLUSTER FOR REGISTER ATTACHMENT.

BLACK INTERIOR.

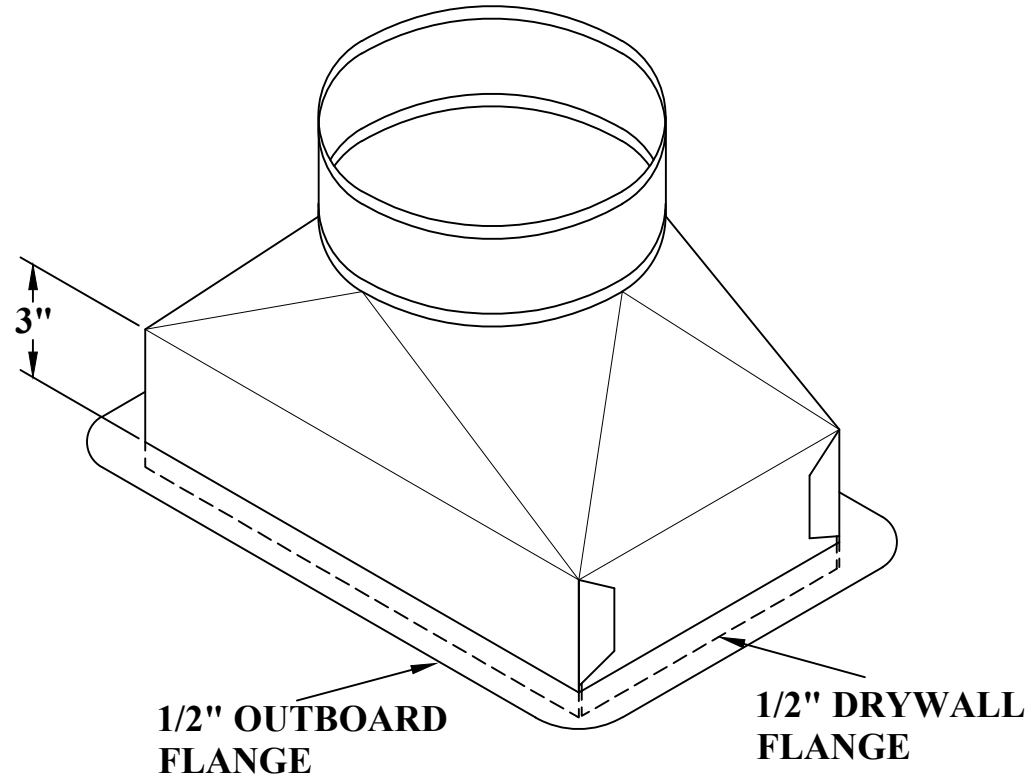

OPTIONS

No. 1242 FRAMED INSULATED BOOT, R-4.2
INSULATION, BLACK INTERIOR.

SPECIAL NOTES

INTERNAL INSULATION USED MEETS THE REQUIREMENTS OF ASTM C 1338 (FORMERLY ASTM C 665)
STANDARD TEST METHOD FOR FUNGI RESISTANCE.