



CROWN

 PRODUCTS COMPANY, INC.

6390 Phillips Highway
 Jacksonville, FL 32216
 Phone (904) 737-7144

DIMENSIONAL DATA

SIZES AVAILABLE: 4" THROUGH 20" DIAMETER

COLLARS ARE 3" LONG FROM FLANGE TO EDGE OF COLLAR.

FABRICATION DATA

FABRICATED FROM HOT DIPPED GALVANIZED STEEL SHEET OF LOCK FORMING QUALITY PER ASTM-653 CS TYPE B.

SIZES 4" THROUGH 12" = 30 GAUGE
 SIZES 14" THROUGH 20" = 28 GAUGE

FEATURES

NEW - EASY BENDS TABS (1/3 LESS TABS TO BEND)
 3/4" OUTBOARD FLANGE INTERNALLY SEALED WITH HOT MELT MASTIC.
 TABS ARE DESIGNED FOR 1" AND 1-1/2" THICK DUCT BOARD.
 MANUAL VOLUME DAMPER: SIZES 4" - 10" HAVE 1/4" REGULATOR, SIZES 12" - 20" HAVE REINFORCED DAMPER AXIS AND 1/4" REGULATOR.
 SCOOP PENETRATES INTO TRUNK DUCT AIR STREAM.

OPTIONS

SPECIFICATION DATA SHEET

Date: 05/08/03 rev. Drawn by: M.D.C.

MODEL No. 616-DS
 TAB COLLAR
 WITH SCOOP AND MANUAL VOLUME DAMPER

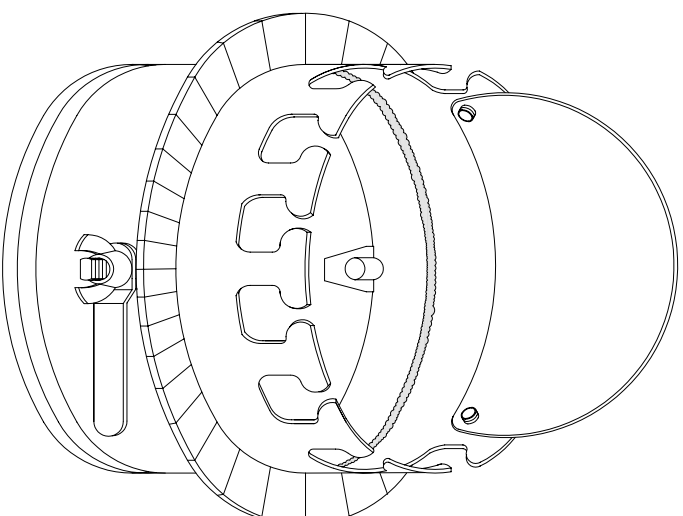

SPECIAL NOTES

HOT MELT GASKET USED TO SEAL FLANGE BEARS FIRE HAZARD CLASS 1, FLAME SPREAD LESS THAN 25, SMOKE DENSITY LESS THAN 50.